

**The latest Analytical Instruments and  
Scientific Instruments gathered at Makuhari !!**



***JAIMA EXPO:-2010* SIS2010**

**Exhibit Service Manual**

## Important Changes for JAIMA EXPO 2010 / SIS 2010

This Service Manual can be obtained from the JAIMA EXPO 2010 / SIS 2010 home page at; <http://www.jaimasis.jp/2010/english/entry/index.html> by clicking “Exhibit Service Manual”.

Please carefully read the manual and observe the regulations stated in it. Please hand the Manual to your contractors to observe the regulations.



### [Carpeting the aisle between the opposing booths]

Carpeting the aisle between the opposing booths is prohibited from this year.

### [Wall Regulation]

For Independent Booth, the wall lower than 2.7m can be constructed provided that opening regulation (ref. P17 – P18) was met.

For other booth, the wall should not be constructed on the aisle side.

\*The “wall” is a structure (panels, lattices, curtains and screens) which covers the area between 1.2m to 2m height facing to aisles.

### [Opening regulation of the structures facing aisles] (deregulation, see P17 – P18)

For Independent Booth and Block Booth (larger than 12 blocks), at least two openings wider than 5m are required on the diagonal sides.

For General Booth (2blocks – 11blocks), at least one opening wider than 2m is required.

For the 1 block booth, at least 1 opening wider than 1.2m is required.

### [Rental Meeting Rooms (1st and 2nd floor of the north end of exhibition halls )]

Starting from this year, the meeting rooms on the 1st floor and the lounges on the 2nd floor located at north end of exhibition halls become available for rent. Please apply with the application form attached to this manual then assign the rooms in order of arrival.

#### **The Meeting Rooms at north end 1st floor of the exhibition halls (4 rooms)**

Dates and time: 8/31 – 9/3 four days from 9am to 5pm (daily rental is not available, 4days rental only)

Purpose: waiting room, meeting, storage etc.

Furniture: desks and chairs (exhibiting the goods is prohibited)

\*When other furnishings are required, ask for organizer.

#### **The Lounges at north end 2nd floor of the exhibition halls (3 rooms)**

Dates and time: 9/1– 9/3 from 9am to 5pm (hourly rental available)

Purpose: meetings only

Furniture: chairs and tables (for 4 people × 2 sets)

Refrigerator (with 12 bottles of tee and water)

# Table of Contents

<b>Access to Exhibition Site</b> .....	2
<b>Layout of the venue</b> .....	3
<b>Overview</b> .....	4
<b>Overall Timetable</b> .....	5
<b>General Information</b> .....	6-8
<ul style="list-style-type: none"> <li>1. JAIMA EXPO / SIS Secretariat Office</li> <li>2. Exhibit Control</li> <li>3. Handling of foreign goods with bonded exhibition</li> <li>4. Exhibits containing inventions before applying for Industrial Property Right</li> <li>5. Overtime work</li> <li>6. Nametags for exhibitors and contractors</li> <li>7. No photography policy</li> <li>8. Displays and expressions in the booth</li> <li>9. Rental service for lead retrieval system</li> <li>10. Disposal of wastes</li> <li>11. Meal and beverage vouchers</li> <li>12. Others</li> </ul>	
<b>New Technology Seminars</b> .....	9-10
<b>Exhibit Guidelines</b>	
<b>1. Installation and Dismantling (I&amp;D)</b> .....	11-12
<ul style="list-style-type: none"> <li>(1) I&amp;D time frame</li> <li>(2) I&amp;D by vehicle</li> <li>(3) I&amp;D vehicle routing</li> <li>(4) Delivery of exhibits to booth using Parcel Transporter</li> <li>(5) I&amp;D on show dates</li> <li>(6) Exhibitors' entering the venue during show dates</li> <li>(7) Wastes</li> <li>(8) Others</li> </ul>	
<b>2. Exhibition and Decoration</b> .....	13-20
<ul style="list-style-type: none"> <li>(1) Booth locations</li> <li>(2) Carpeting by organizer .....</li> <li style="padding-left: 20px;">13</li> <li>(3) Booth specification .....</li> <li style="padding-left: 20px;">13-14</li> <li style="padding-left: 40px;">1) Basic Booth .....</li> <li style="padding-left: 60px;">13</li> <li style="padding-left: 40px;">2) Independent Booth</li> <li style="padding-left: 60px;">3) Construction .....</li> <li style="padding-left: 80px;">14</li> <li>(4) Booth Decoration <ul style="list-style-type: none"> <li>1) Registration of decoration contractors</li> <li>2) Construction and dismantling dates .....</li> <li style="padding-left: 20px;">14-15</li> <li>3) Disposal of waste materials .....</li> <li style="padding-left: 20px;">15</li> </ul> </li> <li>(5) Construction Reminders <ul style="list-style-type: none"> <li>1) Reminders for system panel booths</li> <li>2) Parapet display</li> <li>3) Prohibition of carpeting the passage .....</li> <li style="padding-left: 20px;">15</li> <li>4) Construction of ceiling or two-floor structures</li> <li>5) Prohibition of direct fabrication .....</li> <li style="padding-left: 20px;">15-16</li> <li>6) Loading &amp; Unloading by Vehicles</li> <li>7) Decorating materials .....</li> <li style="padding-left: 20px;">16</li> <li>8) Restrictions on decoration.....</li> <li style="padding-left: 20px;">16-18</li> <li style="padding-left: 40px;">a) Height restrictions</li> <li style="padding-left: 40px;">b) Walls on the aisle side</li> <li style="padding-left: 40px;">c) Openings on the structures facing aisle side</li> <li>9) Regulations on presentations within the booth and noise prevention</li> <li>10) Floor work</li> <li>11) Others .....</li> <li style="padding-left: 20px;">18-20</li> </ul> </li> </ul>	
<b>3. Electricity</b> .....	21-22
<ul style="list-style-type: none"> <li>(1) Applying for power supply</li> <li>(2) Power specifications</li> <li>(3) Electrical installation costs</li> <li>(4) Electricity charges</li> <li>(5) Reminders regarding electric installation work within your booth</li> <li>(6) Hours of power supply to your booth</li> <li>(7) 24-hour power supply</li> <li>(8) Others</li> </ul>	
<b>4. Fire Safety</b> .....	23
<ul style="list-style-type: none"> <li>(1) No smoking policy</li> <li>(2) Use of open flames and hazardous substances</li> <li>(3) Other reminders</li> </ul>	
<b>5. Phone/Fax/ADSL/ISDN/Optical Fiber connection</b> .....	24
<ul style="list-style-type: none"> <li>(1) Application</li> <li>(2) Charges</li> <li>(3) Notification of phone number</li> <li>(4) Others</li> </ul>	
<b>6. Servicing Foods or Beverages</b> .....	25
<b>7. Water Supply, Drainage and Compressed Air</b> .....	25
<ul style="list-style-type: none"> <li>(1) Installation</li> <li>(2) Costs</li> <li>(3) Others</li> </ul>	
<input type="checkbox"/> <b>Attached Forms</b>	
<ul style="list-style-type: none"> <li>1. Decorator Registration Form</li> <li>2. Application for Special Construction</li> <li>3. Light and Power Installation Blueprint</li> <li>4. Application for the Use of Open Flames and Hazardous Substances</li> <li>5. Application for Temporary Phone, Fax, ADSL, ISDN and Optical Fiber connection</li> <li>6. Application for the Use of Drayage Machinery</li> <li>7. Confirmation Request for Products Needing Application for Industrial Property Right</li> <li>8. Application for Change of Address or Number of Nametags for Exhibitors &amp; Contractors</li> <li>9. Application for Bar Code Registration System</li> <li>10. Application for Meeting Rooms and Guest Lounges rental</li> <li>11. Notification of Foods &amp; Beverages Service</li> </ul>	
<input type="checkbox"/> <b>List of contact addresses of the Secretariat and Companies recommended by the Exposition Organizer</b>	

## Access to Exhibition Site

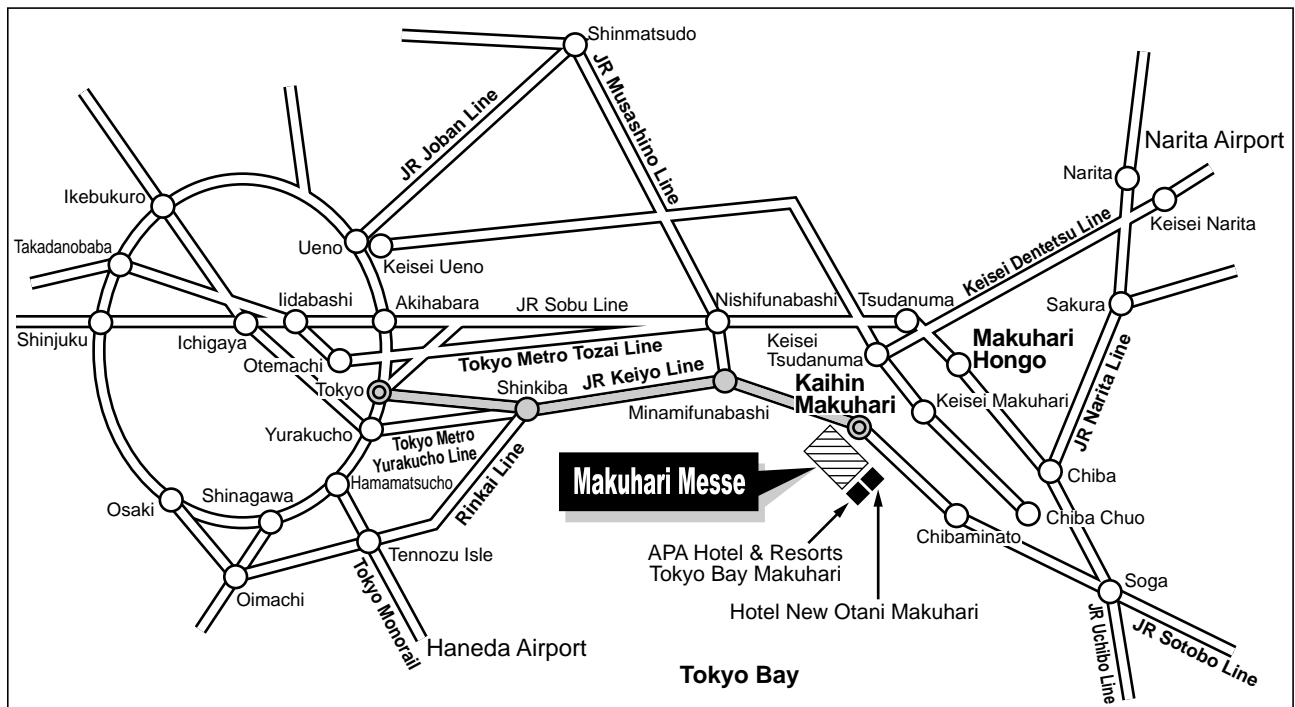

### ■ By train:

- Take the JR Keiyo Line to Kaihin Makuhari Station. (Approx. 34 minutes from Tokyo Station and approx. 12 minutes from Soga Station by a rapid train) Makuhari Messe is about 10-minutes walk from the station.
- Take the JR Sobu Line to Makuhari Hongo Station. (Approx. 40 minutes from Akihabara Station) Makuhari Messe is about 15-minute bus ride from the station.

From Narita Airport (New Tokyo International Airport)

- Take the airport limousine bus service, Approx 30 minutes from Narita Airport to Makuhari Messe area hotels, by Keisei Bus or Chiba Commuter Bus. (1,100 yen as of December 2009)
- Take Keisei Line (train) to Tsudanuma, transfer to Keisei Chiba Line to Makuhari Hongo (Approx 53 minutes), then take Keisei Bus to Kaihin Makuhari (Approx 15 minutes) or take a taxi.

**A shuttle bus service is available between the show venue and Makuhari Hongo Station via Kaihin Makuhari Station. Buses are free of charge and run every 5 to 10 minutes..**

\* Some buses do not stop at Kaihin Makuhari Station. Please visit our official web site for details.

(<http://www.jaimasis.jp/english/index.html>)

### ■ By car: (We recommend the public means of transportation.)

- From Central Tokyo
  - Take Higashi-Kanto motor way (toll) to Wangan-Chiba Junction (Approx 40 minutes from both downtown Tokyo and Haneda Airport (Tokyo International Airport)). About 5 minutes from the junction following the signs to "Makuhari-Messe".

\* Parking lots are all charged.

Please refer to the following web site for parking information:

[http://www.m-messe.co.jp/access/parking\\_e.html](http://www.m-messe.co.jp/access/parking_e.html)

**Layout of the venue**

- [Rooms #1 for New Technology Seminars]  
APA Hotel & Resort Tokyo Bay Makuhari  
Tokyo Bay Makuhari Hall, Rooms No. 1 to 11 (2nd floor)  
(Room Capacity for A-6 is 200, Other Rooms 100)

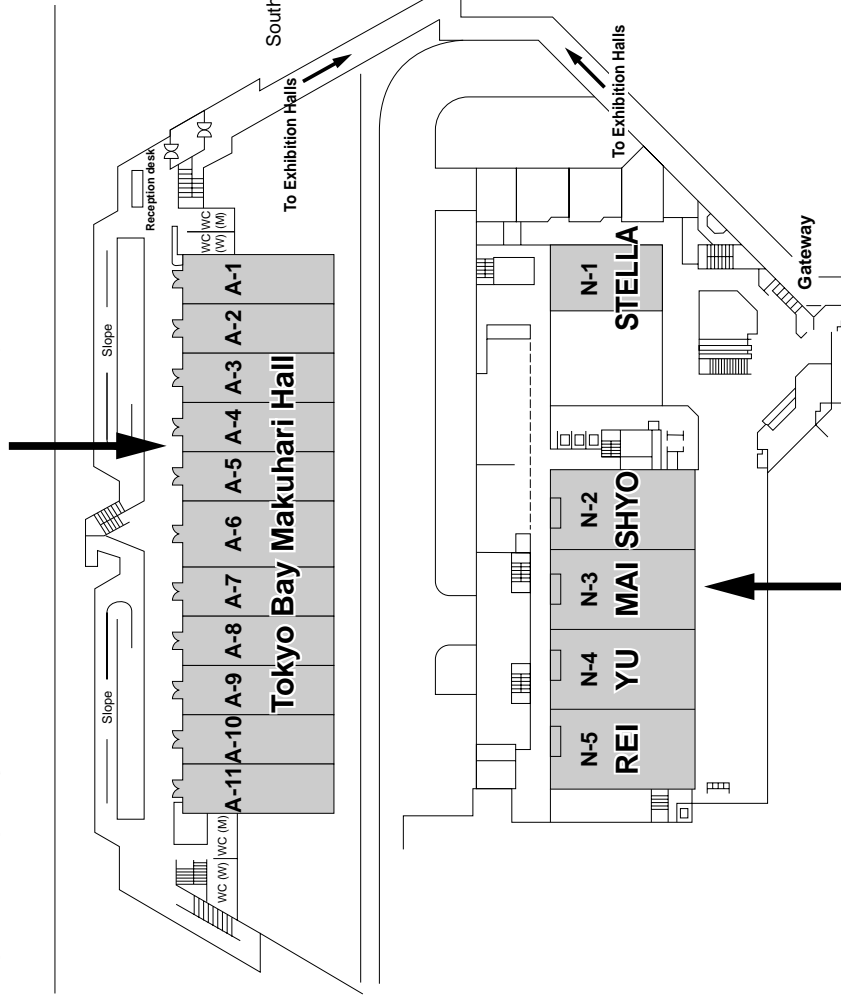

- [Rooms #2 for New Technology Seminars]  
Hotel New Otani Makuhari  
STELLA, Room N-1. SHYO, Room N-2.  
MAI, Room N-3. YU, Room N-4. REI, Room N-5. (2nd floor)  
(Room Capacity for N-1 is 100, Other Rooms 200)

- [Exhibition Halls JAIMA EXPO 2010/SIS 2010]  
Halls 4, 5, 6, 7 and 8 in the Makuhari Messe  
International Exhibition Hall

- Mini Solution Corner
- Mini Solution Exhibition Corner
- Mini Solution Catalogue Corner
- JST Booth 2010
- Research Organization Corner
- Academic Association Corner
- International Organization Corner  
(U.S. Pavilion, China Pavilion,  
Gambica Corner and more ...)
- News & Magazine Corner

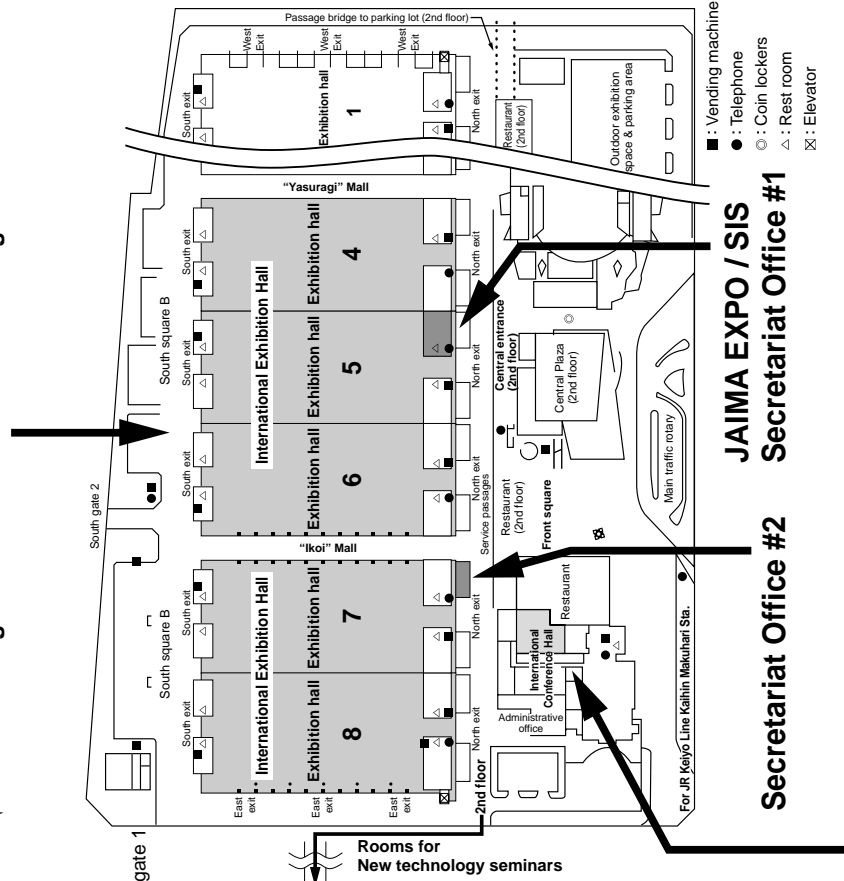

- [Rooms for JAIMA Conferences and Tokyo Conferences]  
International Conference Hall in Makuhari Messe
- Secretariat Office #2
- JAIMA EXPO / SIS  
Secretariat Office #1

---

# Overview

---

- 1) Title: JAIMA EXPO 2010 / SIS 2010
- 2) Organizer: Japan Analytical Instruments Manufacturers' Association  
Japan Federation of Scientific Instruments Associations
- 3) Sponsors (planned): Ministry of Economy, Trade and Industry / Ministry of Education, Culture, Sports, Science and Technology / Ministry of Environment / Ministry of Agriculture, Forestry and Fisheries / Japan Society for Analytical Chemistry / Chemical Society of Japan / U.S. Commercial Service, Embassy of the United States of America / Embassy of Canada / British Embassy, Trade & Investment Department / The Embassy of Republic of Korea / Australian Embassy, Tokyo / Interchange Association / Spectroscopical Society of Japan and others
- 4) Public Relations: • Internet • Newspaper, magazines and posters  
• Delivery of programs to the visitors in advance  
• On-site advertisement using public announcements and bulletin boards
- 5) Admission fee: Free

## I JAIMA EXPO 2010 / SIS 2010

- Dates: September 1 – September 3, 2010 (3 days, Wed. – Fri.)  
Time: 10:00 – 17:00  
Venue: Opening Ceremony begins at 9:40 a.m. on September 1 at the show venue.  
International Exhibition Halls No. 4, 5, 6, 7, and 8, Makuhari Messe  
2-1 Nakase, Mihama-ku, Chiba City, Chiba Prefecture 261-0023 Japan  
URL: <http://www.m-messe.co.jp/>
- Exhibiting companies: 420 (as of May 20, 2010)  
Exhibition booths: 1320 (as of May 20, 2010)

## II New Technology Seminars

- Dates: September 1 – September 3, 2010 (3 days, Wed. – Fri.)  
Time: 10:30 – 16:55  
Venue (planned): Tokyo Bay Makuhari Hall, APA Hotel & Resorts Tokyo Bay Makuhari (adjacent to exhibition halls)  
Hotel New Otani Makuhari (adjacent to exhibition halls)
- Participating companies: 93 (as of May 20, 2010)  
Themes: 296 (as of May 20, 2010)

## III JAIMA Conferences

- Dates: August 31 – September 3, 2010 (4 days, Tues. – Fri.)  
Time: 10:00 – 17:00  
Venue: International Conference Hall, Makuhari Messe  
Number of groups participating: 22 (as of May 20, 2010)  
Themes: 42 (as of May 20, 2010)

## IV Co-organized Meetings: Tokyo Conferences

- Organizer: Japan Analytical Instruments Manufacturers' Association,  
Japan Society for Analytical Chemistry
- Dates: September 1 – September 3, 2010 (3 days, Wed. – Fri.)  
Venue: International Conference Hall, Makuhari Messe

## © Secretariat Office: JAIMA EXPO 2010 / SIS 2010 Organizing Committee,

att. **Japan Analytical Instruments Manufacturers' Association**

Sakura Bldg., 3rd Floor, 1-10-1 Kanda-Nishiki-cho, Chiyoda-ku, Tokyo, 101-0054 Japan

Phone: (03) 3292-0642 Fax: (03) 3292-7157

(Local offices are set up in the hall #5 and hall #7 from Mon. August 30 to Fri. September 3, 2010)

# Overall Timetable

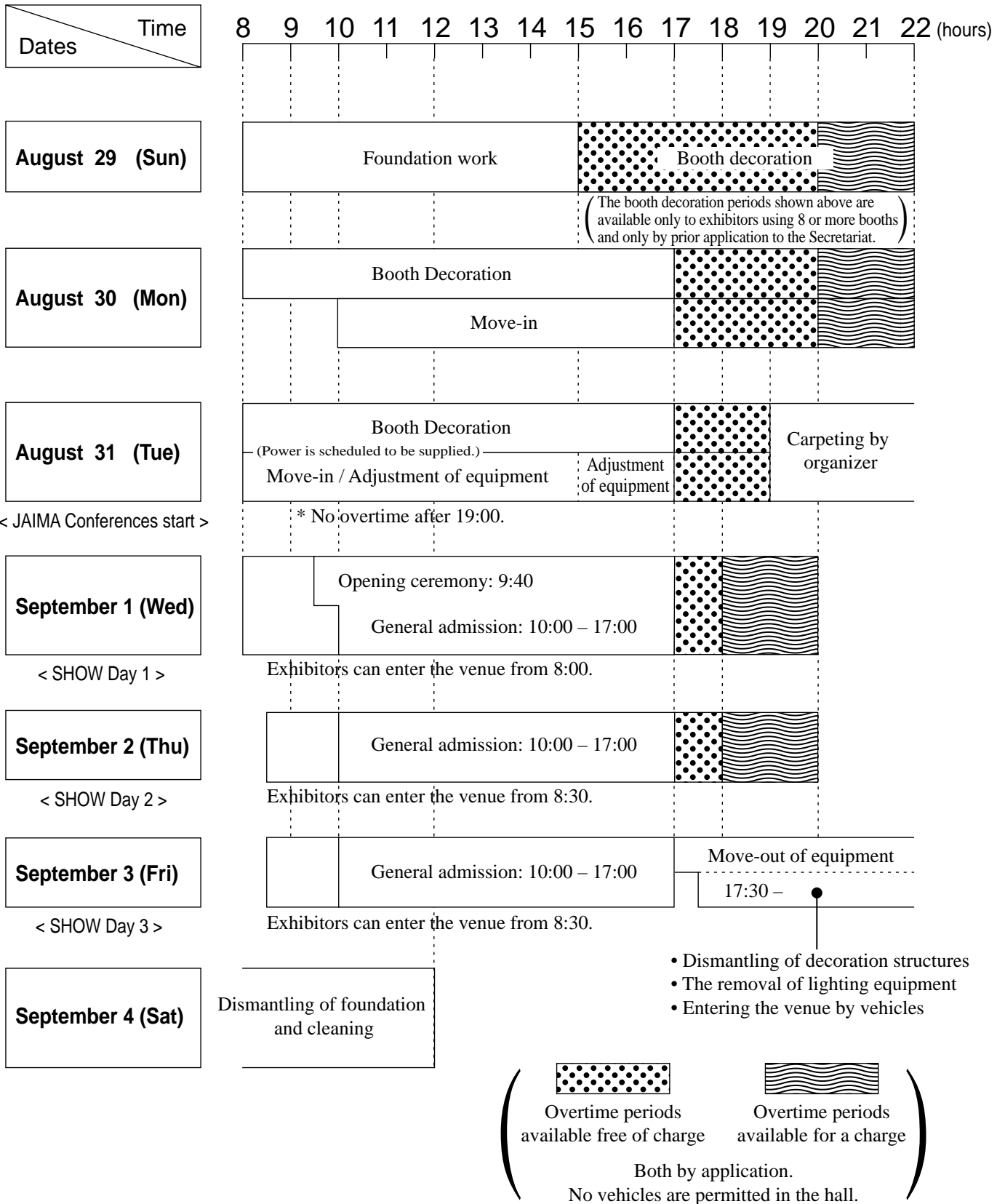

---

# General Information

---

## 1. JAIMA EXPO / SIS Secretariat Office

---

- (1) For safe and smooth operation and for maintaining order in this show, all participating companies and organizations are requested to comply with show regulations and to follow the instructions issued by the Secretariat Office. Your cooperation is highly appreciated.
- (2) From Mon. August 30 through Fri. September 3, 2010, The JAIMA EXPO / SIS Secretariat Offices will be set up in the north office of the International Exhibition Hall 5 and 7, Makuhari Messe. The Office will be in charge of show management and maintenance and of an information service to facilitate its smooth operation and the convenience of its exhibitors and guests.

Office address: International Exhibition Hall 5 and 7, Makuhari Messe  
Nakase 2-1, Mihama-ku Chiba-city, Chiba 261-0023

A direct phone line shall be installed only for the office at hall 5 from Mon. August 30, 2010.

## 2. Exhibit Control (Including Personal Belongings)

---

- (1) The Secretariat Office will provide security guards in the venue during the show. However, the control of exhibits (including personal belongings) is exhibitors' responsibility. In no event will JAIMA EXPO 2010 / SIS 2010 or Secretariat Office be held liable for damaged, stolen, lost, or broken exhibits (including personal belongings).
- (2) In order to avoid theft, exhibitors are requested to manage valuable items under their responsibilities, for example, bringing back or storing them in their own space in the booths.
- (3) The exhibitors are advised to obtain necessary insurance for their exhibits on their own responsibility.
- (4) Exhibitors, who want to use a security service for their own booths (at a charge) from the preparation period to the show period, should directly consult and apply to TEXS K.K., a security company responsible for guarding the show venue. Please note that the Organizer is not involved in any security contracts between the exhibitors and TEXS K.K.  
(F.Y.R: Labor Charge: 2500 JPY/hour (excludes tax & expense). For details, please ask TEXS K.K. as follows)

**TEXS K.K.** (Contact person: Sueda)

Sun Youth Bl. 3rd floor, 5-40-9 Higashi-Ikebukuro, Toshima-ku, Tokyo, 170-0013, Japan

Phone: (03) 3590-6446 Fax: (03) 3590-4001

## 3. Handling of foreign goods with bonded exhibition

---

- (1) We filed an application to obtain permission for the JAIMA EXPO 2010 / SIS 2010 to be a bonded exhibit area. Foreign exhibits (goods) can be displayed by declaring the goods for exhibition to the customs office and by obtaining authorization from the house. ISHIKAWA-GUMI. LTD. (see below) will submit all of your applications to the customs office to obtain exhibit approval at the JAIMA EXPO 2010 / SIS 2010. So, all exhibitors who want to display their exhibits with permission for bonded exhibition are requested to inform the Secretariat Office in advance.
- (2) When you distribute or use brochures and pamphlets from abroad during the show, be sure to get an import approval for goods prior to bringing them into the show venue.  
For details of handling foreign exhibits, follow the instructions given by ISHIKAWA-GUMI. LTD., in addition to the descriptions in this manual.

**ISHIKAWA-GUMI. LTD.** (Contact person: Nozaki)

5-9-4 Higashi-Shinagawa, Shinagawa-ku, Tokyo, 140-0002, Japan

Phone: (03) 3474-8102 Fax: (03) 5460-9841

#### **4. Exhibits containing inventions before applying for Industrial Property Right** ---

JAIMA EXPO 2010 / SIS 2010 is authorized as a “Designated Exhibition” by the Japan Patent Office. Therefore, the exception to Lack of Novelty could be applicable to the products which you will exhibit (3rd paragraph of Article 30 of the Japanese Patent Law, 1st paragraph of Article 11 of the Japanese Utility Model Law, and 1st paragraph of Article 9 of the Japanese Trade Mark Law). Exhibitors planning to exhibit products before submitting an application for industrial property rights and intend to apply for the Exhibit Certificate for the JAIMA EXPO 2010 / SIS 2010, are required to submit “Confirmation Request for Products needing Application for Industrial Property Right” (Form 7) to the Secretariat. (Submission dead line: August 2, 2010 (Mon.)) Based on those requests, the Secretariat would examine and confirm their exhibiting products during the show. The Exhibit Certificate shall be issued and given to the exhibitors upon request within seven days after the show.

Please note that simply submitting the application document (Form 7) does not complete the application for the Exhibit Certificate.

For more details, please consult the Secretariat.

Note: This exemption is merely a measure for exceptional cases, therefore, completion of the Industry Property Right application process is highly recommended before exhibiting such products at the show.

#### **5. Overtime work** ---

Please notify the Secretariat Office at Makuhari Messe hall 5 or at hall 7 in advance when the exhibitor must work overtime. (It is to secure necessary arrangements like power supply, air conditioning, security and others.) 50,000 yen per hour per exhibitor (including consumption tax) will be charged for overtime work performed during fee-based overtime periods.

Please see “Overall Timetable” on page 5 for details of the overtime hours.

#### **6. Nametags for exhibitors & contractors** ---

The nametags for exhibitors and their contractors shall be provided and sent out to the exhibitor contact addresses in the beginning of August. (These tags are issued to prevent the unauthorized persons entering the show venue.) All the staff members and demonstrators including contractors must wear nametags at all times. Starting from this year, the contractor badges should be swiped upon entry.

(1) Nametags for Exhibitors

10 tags per 1 booth shall be sent to the contact address in the beginning of August.

(2) Nametags for Contractors

These tags are valid only before and after the show. (August 30, 31, and September 3) Please have your contractors and other vendor workers wear these tags whenever they are in the show premises. 5 (five) tags per 1 booth shall be sent to exhibitors.

Note: When you require to change the number of nametags and the address to which the nametags are sent, please apply by filling out the “Application for Change of Address or Number of Nametags for Exhibitors & Contractors” (Form 8) (dead line: July 16 (Fri.)). For security reasons, we do NOT accept the application directly from your contractors.

#### **7. No photography policy** ---

Photography and video filming is prohibited in the venue, except for QR code reading using mobile phone camera and press personnel holding a permit issued by the Secretariat. No photography policy includes a case where personnel or related people of an exhibitor taking photographs of their own booths, except for those who are holding a permit issued by the Secretariat. (A permit will be issued at the JAIMA EXPO / SIS Secretariat Office in the International Exhibition Hall 5 or at hall 7, Makuhari Messe.) When the visitors or personnel of other exhibitors found photographing without permission, please ask them to stop immediately.

## 8. Displays and expressions in the booth (including presentations)

Please refrain from using displays and/or expressions that would compromise the healthy development of our Associations. Please do not make presentations using bursting sound, lights and smokes, which other exhibitors and visitors might mistake for an accident or a emergency. In addition, we ask booth attendants to refrain from wearing inappropriate clothing, which is harmful for common sense and social order. For details, please refer to pages 18 to 20.

## 9. Rental service for Lead Retrieval system

The Lead Retrieval Bar Code system was renewed this year to make two options available for exhibitors. Please contact TAIYODO Co., Ltd. for details. Please note that the organizer shall not be responsible for any personal data leakage or loss in this system.

### (Plan A) from ¥12,600 for the set of one handy terminal and PC software

The leads gathered by handy terminal would be stored at the server by uploading the data at data center on the venue. Then, exhibitor can download the visitor data from the exhibitor site by logging in with ID & PW provided by TAIYODO Co., Ltd. Data can also be obtained in the USB memory.

### (Plan B) from ¥31,500 for one bar-code reader, PC with software and a printer

The equipment lead data can be managed at exhibitor booth, where the collected data can be stored and manipulated in the provided PC.

The equipment lease agreements need to be signed between exhibitors and TAIYODO Co., Ltd. and any inquiries or questions need to be forwarded to TAIYODO.

#### **TAIYODO Co., Ltd.**

(Contact persons: Taniguchi, Yoshida, Kato and Uchida)  
4 Saiin Kamihanada-cho Ukyo-ku, Kyoto, 615-0007, Japan  
Phone:+81-75-315-8900 Fax:+81-75-322-4576  
E-mail: rms@love.co.jp

## 10. Disposal of wastes

Please be sure to take out all of residual materials and wastes, generated by packaging and decoration during installation and dismantling. Please ask decorators and transport companies to thoroughly take wastes out. In addition, for the disposal of wastes during the SHOW, three collection boxes for recyclable, flammable and nonflammable wastes will be provided near the rest rooms at the north side of each hall.

## 11. Meal and beverage vouchers

If you would like to purchase meal and beverage vouchers, you can obtain them as follows. (For details, please ask Makuhari Messe, Inc.)

### (1) Sales prior to the show based on the remittance of funds (until one month before the SHOW)

You can download the application form for the vouchers from the following website of Makuhari Messe, Inc.

[http://www.m-messe.co.jp/restaurant\\_e.html](http://www.m-messe.co.jp/restaurant_e.html)

### (2) Sales during the show (cash only)

You can purchase vouchers at the reception counter of the International Conference Hall in Makuhari Messe, from 9:00 to 17:30 in exchange for cash during the SHOW.

**Makuhari Messe, Inc.** (contact persons: Suzuki, Fujiwara)  
Nakase 2-1, Mihama-ku, Chiba City, Chiba, 261-0023 Japan  
Phone: (043) 296-0525 Fax: (043) 296-0529

## 12. Others

**Fax:** One fax machine is available at the Secretariat Office for a charge. It is primarily for sending and requires a 100-yen coin. Fax reception is also available, but the Secretariat will not notify the receiving party. You can use a photocopy machine and the Internet (for a charge) at the business center by the side of the Central Hall in Makuhari Messe.

# New Technology Seminars

## 1. Overview

- (1) Dates/Time: September 1 (Wed.) - September 3 (Fri.), 2010, 10:30 - 16:55
- (2) Presentation time: 25 or 50 minutes including Q&A session
- (3) Venue (Planned): Section 1 Tokyo Bay Makuhari Hall, APA Hotel & Resorts Tokyo Bay Makuhari  
Section 2 Hotel New Otani Makuhari

## 2. Capacity & Equipments

- (1) We will provide 11 rooms with the accommodation capacity of 100 people and 5 rooms with the accommodation capacity of 200 people. If applications exceed the venue capacity, we may have to decline some of your applications. Also, the room assignments for the presentations might defer from those announced in advance.
- (2) In each room, lecterns, desk for the lecturer, chair, white board, microphones, speakers, LCD projector, screen, (100" for 100 capacity room, 150" for 200 capacity room), timer for the lecturer, pointing stick, reception desk, table for equipment demonstration and power supply (with one AC 100 V, 50 Hz, 1.5 kW outlet) are available.  
Note: Exhibitors are requested to supply their own OHP and video machines, if required.
- (3) Handouts, questionnaires, and word for word interpreters are to be arranged by the exhibitors, if required.
- (4) We will provide a room where you can test the connection between the LCD projector we provide and the computer you use in advance of your presentation. If you would like to test your equipments in advance, take account of the congestion in the test room, and please be careful so that you finish the test one day before your presentation or at latest 30 minutes before.

## 3. Operation of New Technology Seminars

Organizer will provide assistance by stationing committee staffs at the venue, however, presenters are requested to be responsible for the operation of their sessions by observing the rules and regulations bellow.

- (1) Observing the room capacity  
Exhibitors are requested to observe the accommodation capacity of audience in the rooms (100 or 200 people). Holding a seminar with people exceeding the capacity and with people standing in the room is strictly prohibited. This is for an emergency safety purposes. We appreciate your understanding and cooperation.
- (2) Observing time schedule and program contents
  - 1) Keep your presentation within the allotted time of either 25 or 50 minutes. This allotted time includes lecture, Q&A session, collecting questionnaires, and vacating the room. If the presentation time past the scheduled period, Organizing Committee may order to immediately stop the session.
  - 2) Presenters and reception staff must be available as the designated room 20 minutes prior to the scheduled starting time.

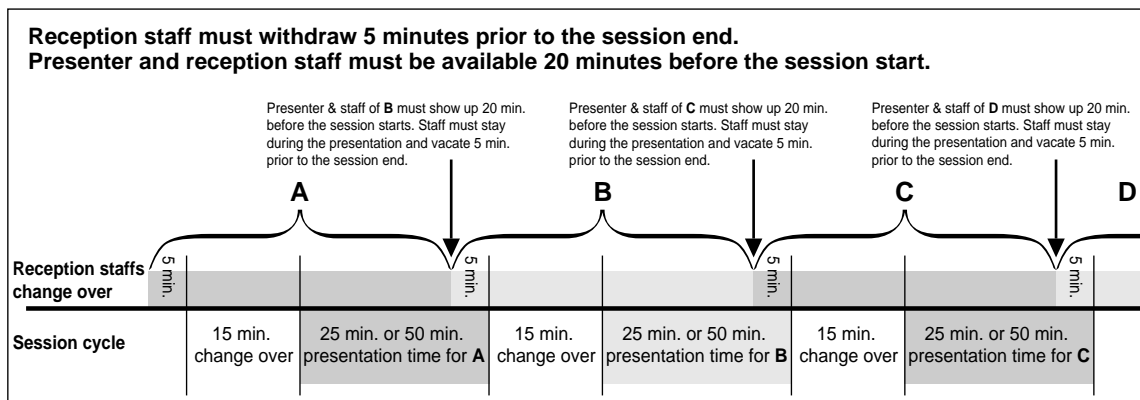

- (3) Reception management, and keeping in order at the reception area
  - 1) Receptionist and assistants are to be provided by the presenters.  
(Organizer would assign 1 to 3 staffs to support smooth operation at the reception area, however, presenters are to be fully responsible for the reception operation including safety and distinguishing the competitors.)
  - 2) If you expect the congestion at the reception counter in the room, please take measures, for example, increasing receptionists.
  - 3) Reception staff are expected to stay during the presentation and withdraw 5 minutes before the scheduled ending time for the smooth transition.
- (4) English Presentation

English presentation can be made. (English only) If you would like to make your presentation in English, please note in your session manuscript as ⟨English/with interpreter (or without interpreter)⟩ so that the visitors would know the presentation language. (Details shall be notified at manuscript input)

When simultaneous interpretation is required, presentation room shall be designated and interpreter & equipments shall be prepared by organizer for smooth transition. Please note that the organizer would NOT assure the quality of interpretation. Exhibitors are expected to contact and discuss with the interpreter agent to prepare for their presentations. For word-by-word interpretation, please arrange at exhibitors' responsibility.

#### **4. Prohibited activities**

- (1) **Cancellation of presentation or change of topic after the manuscript has been submitted.**  
**With some unforeseen reasons, when exhibitor would like to cancel the presentation or change the topic from the submitted manuscript, please assign staff members at the reception of the venue and notify the attendees of the cancellation or change of topic. Please note that the entry fee is NOT refundable.**
- (2) **Handing out gifts and novelty items to the attendees.**
- (3) **Use of hazardous substances, such as pressurized, flammable or toxic gases; chemicals with strong odors; and Type 4 hazardous substances (See page 23).**
- (4) **Use of audio equipments.**
- (5) **Accommodating the audience exceeding the room capacity (100 or 200).**

# Exhibit Guidelines

## 1. Installation and Dismantling (I&D)

Please read and understand following instructions and make sure **not to obstruct other exhibitors while transporting and uncrating the items during I&D.**

**The exhibitor's person in charge must be present during I&D.**

### (1) I&D time frame:

Referring the overall time table on page 5, please complete I&D within the time frame below.

#### 1) Move-in (Installation):

August 30 (Mon) 8:00 AM to 5:00 PM, (Decoration materials) / 10:00 AM to 5:00 PM, (Exhibits)

August 31 (Tue) 8:00 AM to 3:00 PM, (All items)

#### 2) Move-out (dismantling):

September 3 (Fri) 5:00 PM to 12:00 midnight,

Please finish moving everything out including decoration materials during the time frame above.

However, please make sure to observe following rules for safety reasons.

**From 5 PM to 5:30 PM, dismantling the booth structures, removing lights and driving the vehicles into exhibition floor are strictly prohibited. Start such operation after 5:30.**

### (2) I&D by vehicle:

- 1) Use South Gate 2 to enter the hall. The vehicle must leave the hall immediately after loading or unloading.
- 2) Security guards will be stationed at South Gate 2. The "I&D Vehicle Registration (sticker)," to be sent at later date, must be shown on the vehicle's windshield. (This rule also applies to decorators' vehicles.) Vehicles without a sticker may be refused entry to the hall.
- 3) If the hall is congested, the special parking area (Block L) will be used as a waiting area. Please follow the instructions given by the security guard who will guide the vehicles in the area.

### (3) I&D vehicle routing:

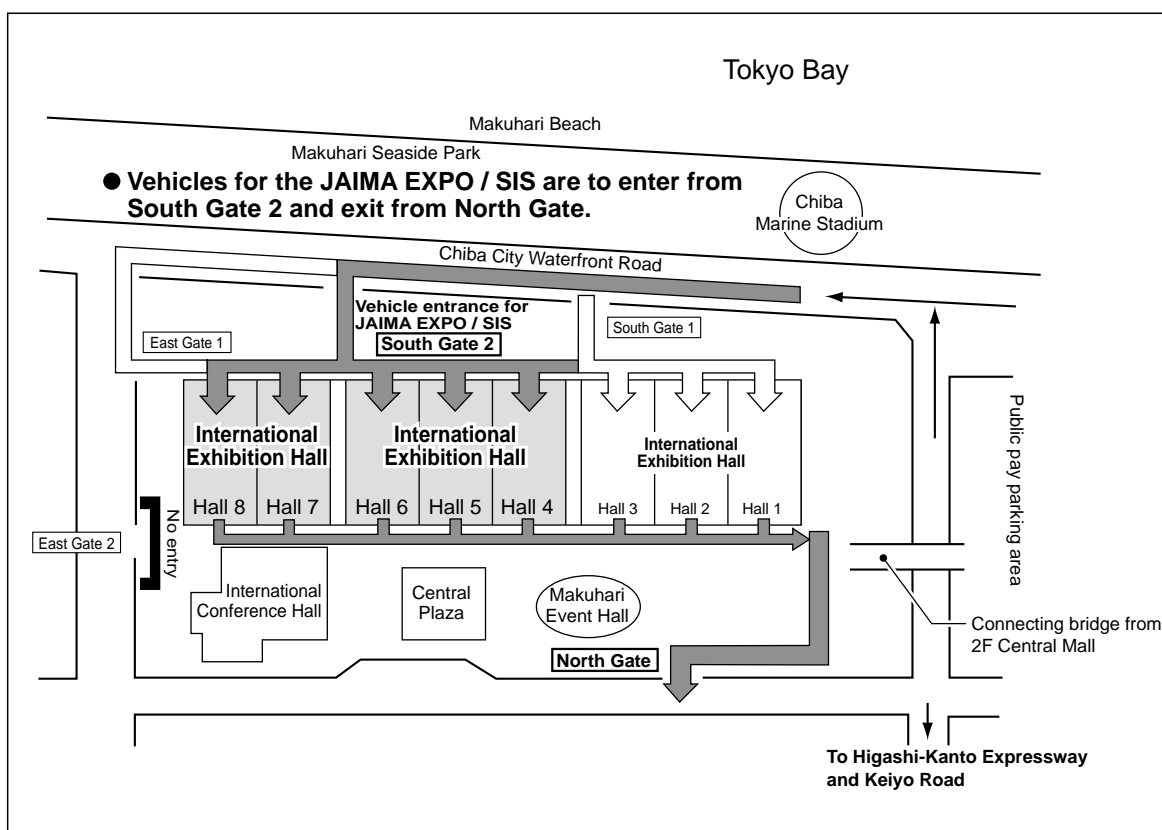

**(4) Delivery of exhibits to booth using Parcel Transporter**

Destination label must show exhibition name (JAIMA EXPO 2010 / SIS 2010), hall #, booth #, exhibitor name, receiving person and his mobile phone, and designate delivery time (during working hours) so that the package can be received securely. Please note that the show office can NOT receive or store the package at all times.

**(5) I&D on show dates:**

As a rule, no I&D is permitted on any of the show dates. If this is unavoidable, report to the Secretariat Office before doing so.

**(6) Exhibitors' entering the venue during show dates**

From this year, exhibitor / contractor badges shall be swiped upon all entry.

September 1 (Wed.): from 8:00 AM / September 2 (Thu.): from 8:30 Am / September 3 (Fri.): from 8:30 AM

**(7) Wastes:**

Make sure to remove all waste materials including packing materials.

**(8) Others:**

The following drayage contractor is available to provide services for a fee. Please contact them directly.

<p><b>Cap K. K.</b> (contact person: Ohkawara) 4-25-18 Higashi-Shinkoiwa, Katsushika-ku, Tokyo, 124-0023 Phone: +81-3-3695-0623 Fax: +81-3--3695-3088</p>
---

## 2. Exhibition and Decoration

### (1) Booth locations

The booth locations will be decided by JAIMA EXPO / SIS Organizing Committee at the end of June, and will be informed to exhibitors by e-mail.

### (2) Carpeting by organizer

- 1) Carpets (color code; NJ-40) will be laid on the public passages in the hall.
- 2) Each of the main passages in Halls 4, 5, 6, 7 and 8 will have an NJ-52 carpet in the middle and NJ-40 carpets on the sides.

General passage: Color approximate to NJ-40



Main passage in Halls 4, 5, 6, 7 and 8  
 Central part: Color approximate to NJ-52 (light gray)  
 Both sides: Color approximate to NJ-40 (light blue)

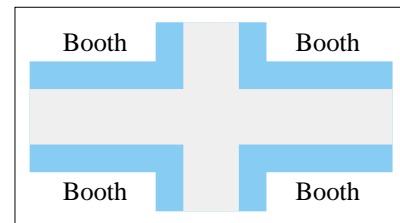

### (3) Booth specification

#### 1) Basic Booth

#### General basic booth diagram

(basic booth with system panel booth specifications)

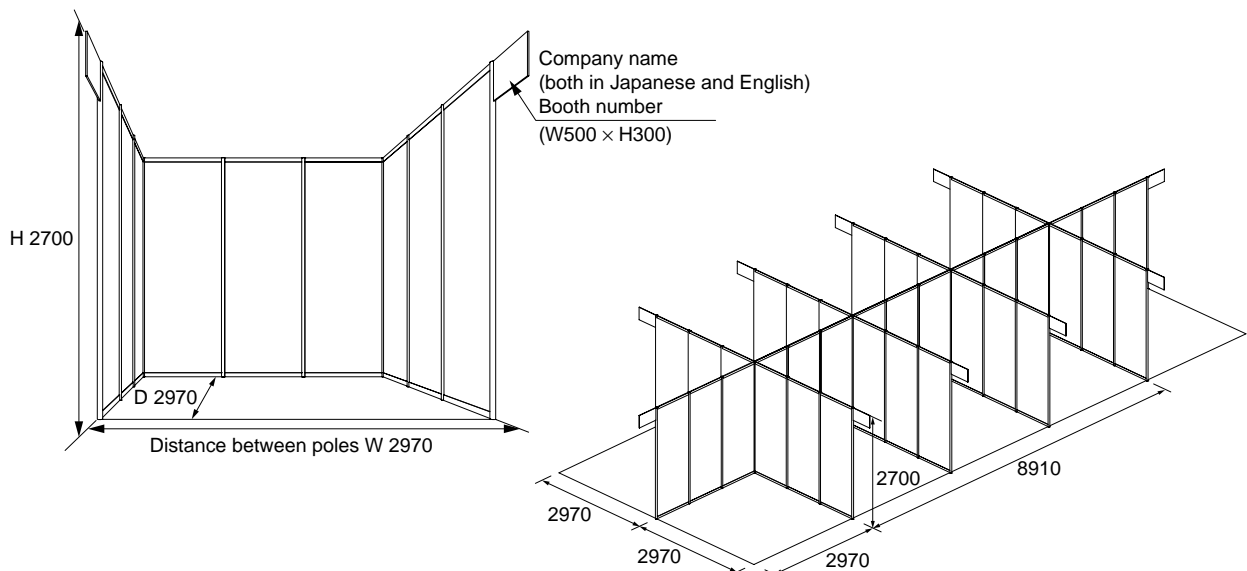

A) Distance between poles: 2.97m (frontage) × 2.97m (depth) × 2.7m (height)

Note: The size of the general basic booth is different from the conventional wooden-panel booth.  
 Please take caution for your construction.

Note: For the height regulation on booth decorations, please see pages 16 to 17.

B) All basic booths are constructed by the system panel booth specifications.

Note: The basic booth with the system panel booth specifications is assembled from poles, beams, and white panel boards (vinyl-coated plywood). (Please see the diagram above.)

C) Attachments are as follows:

- Back walls and sidewalls constructed as partitions

Note: In case of the corner booth, sidewalls on the passage side are not constructed. The exhibitor is allowed to construct the sidewalls below 1.2m height, however, please observe the opening restrictions on page 17.

- Company nameplate protruded from both sidewalls (one place for the corner booth)

The company name and booth number will be shown in black on a styrene board 500 mm wide and 300 mm high (both in Japanese and English).

D) The basic booth does not include carpets, parapets, lighting, outlets, exhibit stands, etc.

(Please see the diagram on the previous page.)

- Package booth and optional equipment

Please see the pamphlet “Package booth and optional equipment”.

Also you can find the related information on the following websites.

<http://www.jaimasis.jp/2010/english/pdf/entry/pbi.pdf>

[http://www.jaimasis.jp/2010/english/pdf/entry/ot\\_cs\\_of.pdf](http://www.jaimasis.jp/2010/english/pdf/entry/ot_cs_of.pdf)

Application deadline: July 23 (Fri.)

E) You can freely decorate within your booth.

For more details, please see the followings.

- When you decorate your booth, please observe the restrictions described article (4) Booth Decoration and (5) Construction Reminders on pages 14 to 20.
- For electrical work and power supply, please see pages 21 to 22, “3. Electricity, (3) Electricity installation costs and (4) Electricity charges.”
- For special decoration requirements in the booth: TEN Corporation (See below) can receive your order. Please consult TEN directly.

## 2) Independent Booth

The booth space exceeding 24 blocks (multiples of 8 booth blocks) are prepared as open space. (There would be no attachment.)

## 3) Construction

A) All basic booth partition walls (except for the independent booth and the booth larger than 16 blocks) will be constructed under the management of the Secretariat. (Decorations inside the booth partitions may be arranged by the exhibitor.)

B) Independent booth and the booth larger than 16 blocks construction must be arranged by the exhibitor.

C) The construction of the basic booth partition walls shall be performed by the company below, under the direction of the Secretariat:

**TEN Corporation** (contact persons: Aoki, Yamazaki)

1-5-9 Kotobuki, Taito-ku, Tokyo, 111-0042 Japan

Phone: (03) 3842-7710 Fax: (03) 3842-7720

**In case of the infringement of the following restrictions and regulations,  
the Organizing Committee may order the changes to be made.**

## (4) Booth Decoration

Booth decorations must conform to the construction reminders, restrictions and rules. The contractors and the exhibitors together are to be fully responsible for any decorations inside the booth.

### 1) Registration of decoration contractors:

Booth decorators must register with the Secretariat by **July 9 (Fri.)** using an attached form 1 “Decorator Registration Form”.

**2) Construction and dismantling dates:**

The construction of decorations must be conducted according to the Overall Timetable (See page 5), and the work must be completed **by 5:00 PM on August 31 (Tue.)**. The dismantling of the decorations must **begin after 5:00 PM on September 3 and be completed by 12:00 midnight**. Please note that dismantling of structures and the removal of lighting equipment must be carried out after 5:30 PM (See page 11).

**3) Disposal of waste materials:**

Please be sure to remove all wastes and residual materials generated by construction and dismantling.

**(5) Construction Reminders**

**1) Reminders specific to system panel booths**

- A) The wall surfaces are not entirely flat. The metallic poles are installed on the wall surfaces of the panels at about 1 m intervals, so convex surfaces approximately at the size of 10mm are formed on the surfaces.
- B) The basic system panels consist of vinyl-coated plywood. Therefore, they should not be decorated nor fabricated.
- C) System panel components (panel boards, poles and beams, etc.) cannot be cut, nailed or drilled.
- D) The use of pins, thumbtacks and double-sided tapes with strong adhesives is not permitted on system panels. (If you use cellophane tapes or other materials, make sure to remove those during dismantling. **THE SYSTEM PANELS MUST BE RESTORED TO THEIR ORIGINAL CONDITION.**)
- E) Use S-hooks or Velcro tape to display panels and other materials.

2) Only the names of registered companies can be shown on the parapet.

3) Exhibitors with opposing booths are not permitted to use their own carpet in public passages that lie between the opposing sections of the booths

**4) Construction of ceiling or two-floor structures** (including the cloth covering at the upper part of the booth)  
Exhibitors can construct these structures, based on prior notification and permission. Even when this construction is within the limit of the local fire regulation, exhibitors are requested to submit the application form to the Secretariat in advance, according to the procedure below.

- A) Please submit the notification document (Application for Special Construction: Form 2) to the Secretariat by July 9 (Fri.).
- B) Also, please submit the “necessary documents” described in a) and b) below, to the Secretariat by August 2 (Mon). The Organizer needs to consult with Makuhari Messe, and apply to and get approval from the local fire department.
- C) The Organizer (Secretariat) will notify necessary information to exhibitors, including instructions and guidance from the fire department. Please be sure to observe them.

**< Necessary documents and reminders >**

a) Construction of ceiling structure (including the cloth covering the upper part of the booth)

Exhibitors who are planning this type of construction must submit two copies of diagrams to the Secretariat by August 3 (Mon), which shows the construction place and the area size.

Note: **Owing to the Fire Regulation, for example, you are basically prohibited** from constructing a stockroom or a dome-shape hanging in a presentation place with an enclosed structure. **However, it may be possible to do this type of construction under the instructions from the fire department if you notify and get approval in advance. If you are permitted, carry out this type of construction by observing the instructions.**

Permitted exhibitors must place a fire extinguisher in a place where it can be easily found and taken out. Also, depending on the construction, it may be necessary to provide a smoke detector.

b) Construction of two-floor structure

Construction of a two-floor structure will require an application stating the measures for accidents, danger and fire prevention. Exhibitors planning this type of construction are required to submit two copies of document materials to the Secretariat by August 2 (Mon), which include drawings (plane

view and elevated view) and documents explaining the purpose of constructing the two-floor structure, construction materials and the evacuation method in case of emergency.

Note: if an accident occurs resulting from the two-floor structure during the construction, during the show or after the show, the exhibitor who constructed this structure will have to be fully responsible.

#### **[Definition of two-floor structure]**

We define a two-floor structure as any multi-layered structure with a floor height of 2.1 m or more.

However, even when the height of the highest floor is lower than 2.1 m, if the first floor is used for passage for visitors, exhibition space, or a staff room, this structure is regarded as a two-floor structure.

#### **5) Prohibition of direct fabrication**

Direct fabrication to the venue building, such as drilling holes into or painting the sashes, floor, walls, columns and passages, and using glue, is prohibited. However, you may install hole anchors on the floor. (Refer to the regulations on pages 19 to 20.)

#### **6) Loading & Unloading by Vehicles**

When loading, unloading, and transporting heavy load by tow trucks and other vehicles, make sure to lay protective boards on the floor. DO NOT place hydraulic outriggers directly on the floor.

#### **7) Decorating materials**

Only flameproof materials can be used to decorate your booth. The use of combustible and ignitable materials is not permitted.

**If your booth is found to be in violation of related fire regulations during inspections carried out by the fire department, you may be requested to remove the items or modify your booth. Please take extra care when decorating your booth.**

- A) Solid boards, plywood, veneers and printed veneers must be flameproof (soak-treated), display a flameproof certification sticker required by Article 4 of the Fire Prevention Law Enforcement Rules by Ministry of General Affairs Order on the front, and have a 5-line marking on the back.
- B) All flammable decoration including curtains, artificial plants, paper and other materials must be flameproof using the same treatment as the materials in A). As a rule, on-site spraying will not be permitted.
- C) The use of petroleum products such as Styrofoam and urethane, flammable chemical fibers and Hong Kong flowers those are not flameproof is prohibited.
- D) Curtains (including accordion curtains) and carpets in the booth must be flameproof. Display the flameproof certification sticker required by the Fire Prevention Law Enforcement Rules on a readily visible location.

#### **8) Restrictions on decoration**

##### **A) Height restrictions**

The exhibitors those would like to construct decorations higher than 2.7m are required to submit the Application for Special Construction (Form 2), before July 9 (Fri.), and also submit two sets of construction drawings before August 2 (Mon.) to the secretariat office.

##### **a) General booths**

- The height of booth interior decoration is to be no higher than 3.6m from the floor level (except for the independent booth, see below). Please note that the area that may be constructed up to this height is the area inside the exhibitor's own booth set back (70cm) from the passage or an adjacent exhibitor's booth.
- The area within 70cm from the passage the wall or structure up to 1.2m height may be constructed except the pillars for parapet. When the space used not for the visitors only (i.e. storage space) was constructed, the height limitation shall be 2.7m even within the set back area, only when it conforms opening (wall) regulations below. The width of such space shall be no wider than 1/3 of the booth length.

- The height limitation within the set back area facing to adjacent booth (not facing the passage) shall be 2.7m.

b) Independent booths

When independent booths are located at the end row, seen from the front entrance of the venue, its height is no more than 6m above floor level. However, when independent booths close to each other are located front and back in a row, the height of the front-side independent booth (at the second row from the end row) is allowed to be no more than 5m.

- As mentioned above, the area that may be constructed up to a height of 6m or 5m is the area inside an exhibitor's booth that is set back from the passage by 70cm.
- The area within 70cm from the passage and adjacent booth may be constructed up to a height of 2.7m.

c) Signs displaying company names and floating materials (balloons) are regarded as structures.

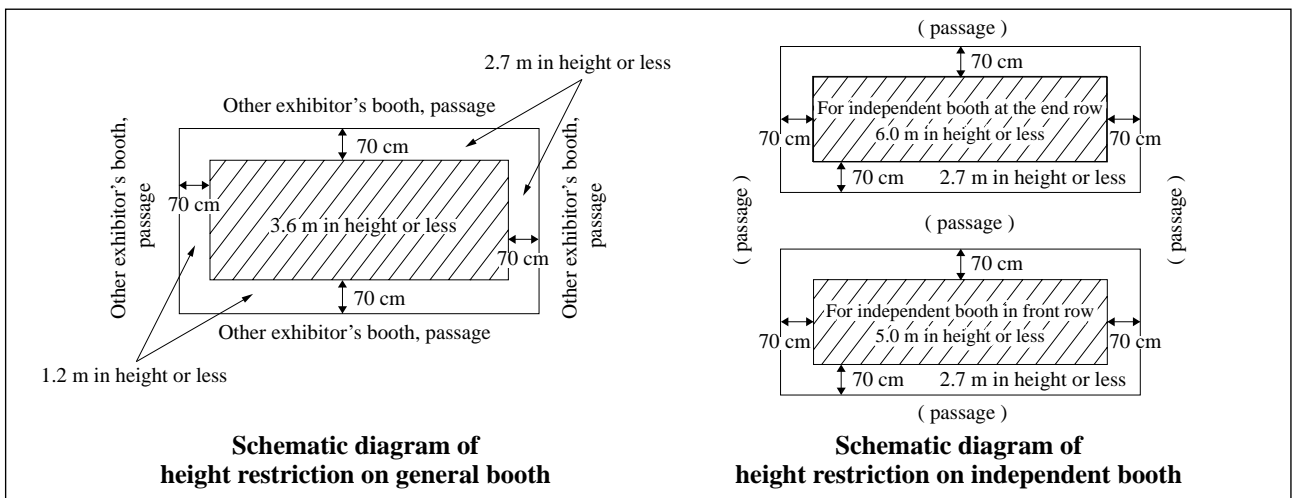

B) Passage side Wall regulations

- Independent Booth: The Wall lower than 2.7m may be constructed at the passage side of independent booth, provided that those walls observe Opening Requirements stated below.
  - All other general booth: Construction of the wall at passage side is prohibited.
- The Wall means any structure constructed within the set back area that disturbs higher than 1.2m area, the structure includes boards, slits, grids, curtains or any other material that block the sight.

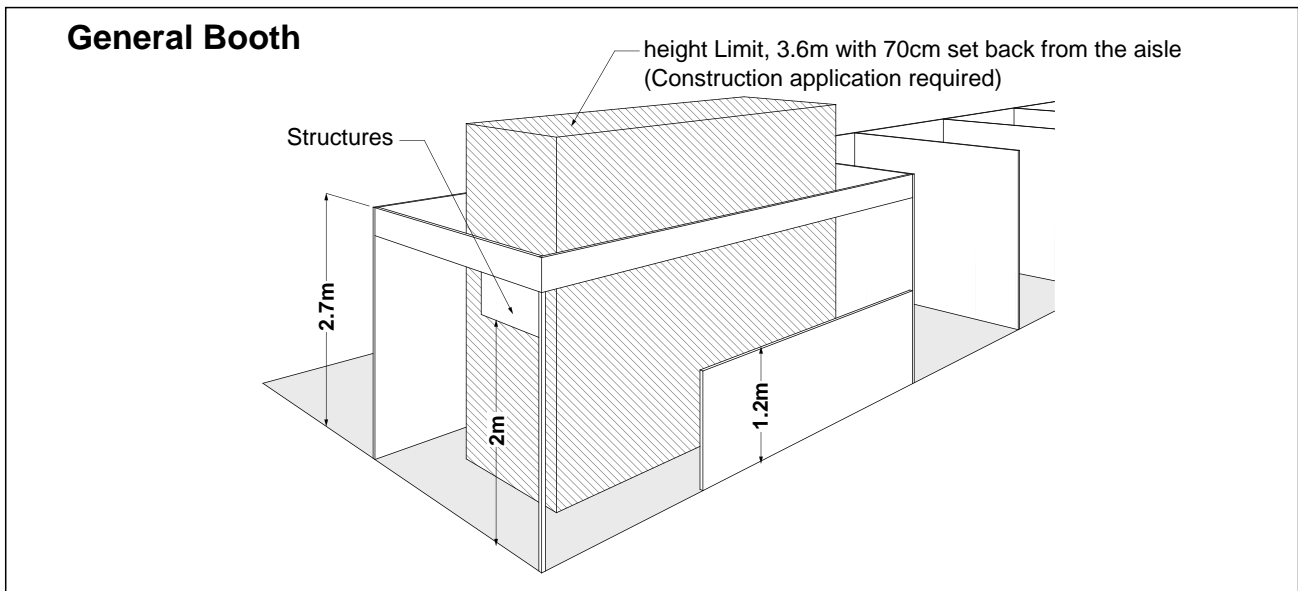

**C) Opening Requirements at the passage side**

A full opening is defined as an opening that provides free traffic of the visitors.

a) Independent Booth and the Block Booth (larger than 12 booths)

More than two openings wider than 5m are required on the two deferent sides of the booth.

Note: “On the two deferent sides of the booth” means either area (1) and (3) or area (2) and (4). When one opening was constructed at (A1), then the other opening shall be either on (B2) or (C1).

This measure is to secure the two deferent escape routes in case of emergency.

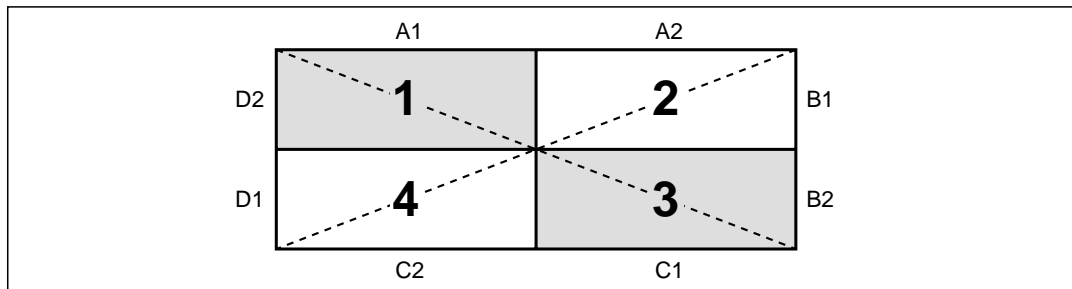

b) General Booth (larger than 2 booths, smaller than 11 booths)

At least one opening wider than 2m is required.

c) General Booth (1 booth)

At least one opening wider than 1.2m is required.

**[Summary of Full Openings]**

To secure the free escape routes in case of emergency, the openings at the passage side walls of the booths are required to observe the regulations as summarized here.

The wall means any structure that blocks the area higher than 1.2m constructed within the 70cm set back area, and the opening means the passage that provides free traffic of the visitors.

		Independent booth	Block booth (over 12 booths)	General booth (2~11 Blocks)	1 booth
walls lower than 2.7m	inside 70cm set back	○	×	×	×
	outside 70cm set back	○ 6m or lower (5m or lower)	○ 3.6m or lower	○ 3.6m or lower	○ 3.6m or lower
Width of Opening		5m or wider (at least two, on different sides)	5m or wider (at least two, on different sides)	2m or wider at least one	1.2m or wider at least one

**9) Regulations on presentations within the booth and noise prevention**

- A) When conducting presentations that involve a narrator with audio assistance from a monitor or screen, the distance between the monitor – measured at a right angle from the center of the face of the monitor – and the edge of the booth must be at least 5m. The distance between the monitor's edges and the edges of the booth must be at least 1m. A seating area must be available within the booth and opened to visitors.
- B) When conducting presentations with sound effects from a monitor or screen without a narrator, the distance between the monitor – measured at a right angle from the center of the face of the monitor – and the edge of the booth must be at least 2m. The distance between the monitor's edges and the edges of the booth must be at least 1m. A seating area must be available within the booth and opened to visitors.
- C) During the exhibit, do not create noise that will adversely affect other exhibitors. In particular, keep the volume of videos and microphones at a prudent level.
  - a) If external speakers are used, point these inwards and never point them towards the passages. Please make sure not to disturb other exhibitors' activities.
  - b) When you place or embed a speaker either on the floor or in a constructed structure, do not place them facing the passage. Adjust its angle and position so that it faces toward your booth. Please carry out installation by taking the surroundings into consideration.

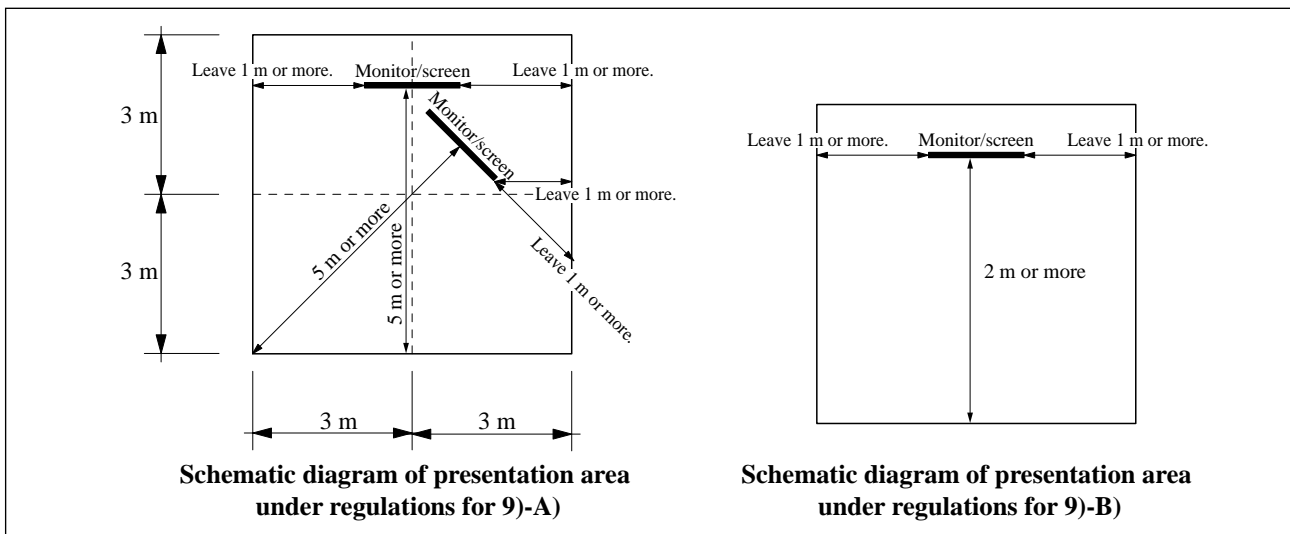

E) During presentations by narrators (including employees of your company), passages may not be used as standing room for your audience. This is important from an emergency safety standpoint and also in terms of avoiding any inconvenience to other visitors. Make sure to design and construct your booth so that there is enough room. In this case also, make sure that all speakers face toward your booth. Please observe the regulation of speaker installation as stated in article C).

**When you prepare ten chairs that accommodate ten people, for example, we anticipate that the number of audience will not be more than 10. If more than 10 participate, be sure to control the participants by guiding them smoothly into your booth. If the Organizing Committee judges that your participants standing on the passage disturbing other visitors' free traffic, and that this situation did not improve even after the official warning is placed, the Committee may suspend your presentation.**

F) The sound level generated within a booth must not exceed 70dB when measured at 2m from the front edge of the booth.

**■ Summary of regulations on presentations**

Narrator	Sound	Monitor/screen	Distance opened to visitors within booth		Speaker
			From the front	From the edge	
○	○	○	more than 5 m	more than 1 m	Point it inside 70 dB or less
×	○	○	more than 2 m	more than 1 m	Point it inside 70 dB or less
×	×	○	Nothing	Nothing	—
×	○	×	—	—	Point it inwards 70 dB or less

G) Please refrain from calling visitors into your booths on the passage.

H) In case of instruments demonstration, please take necessary measures to lower the operation noise (bursting sounds, squeaking or high frequency noise ... even if the noise level was within the limitation) so that those would not disturb other exhibitors.

I) Presentations like below are prohibited

- a) Making loud noise, using flash lights and smoke, to avoid misleading exhibitors and visitors as an accident or a disaster.
- b) Sounding bells or horns (except the recorded music to be broadcasted within the booth at the level lower than 70db limitation.)

- c) Projecting your company name, product name, or company sign (logo) onto the passage using a projector.
- d) Using the lighting equipment such as laser light and/or flushing light, which might impair eyesight of other visitors.
- J) Please refrain from wearing inappropriate clothing for demonstrators, which might be harmful for the sound development of JAIMA or JSIA.
- K) In cases of infringement, the Organizing Committee may order these activities to be suspended or changes be made.

#### 10) Floor work

- A) The only permitted form of direct fabrication to the venue is the installation of hole anchors.
- B) If you plan to embed hole anchors in the floor of the venue, please observe the following instructions:
  - a) Submit the “Application for Special Construction (Form 2)” attached to the end of this brochure, by **July 9 (Fri.)** and two copies of your blueprint by **August 2 (Mon.)**, to the Secretariat.  
We will file applications en bloc to Makuhari Messe, Inc. (Please note that, notwithstanding your filing of an application, some construction work might not be permitted for structural and other reasons.)
  - b) The illustration below shows the floor construction. The hole anchors must be no longer than 80 mm and no thicker than 12 mm, so that they will not disturb the PC floorboard.
  - c) Anchors are not to be embedded in the floor pit lid area or in the pit.
  - d) If you fabricate the floor, you must restore the floor to its original condition immediately after the show. (See the illustration below.)
  - e) As a method of restoration, anchor bolts may be left in the floor by cutting the bolt head. All protrusions above the floor surface must be sanded down to the floor level. Do not hammer the anchors into the floor or use gas-arc cutting.
  - f) The Secretariat will send a bill to the company later, which charges a floor damage fee of 1,300 yen per anchor bolt.
  - g) Change after application for anchor bolt  
If construction changes such as floor construction occur after submitting the application for special construction, please inform the Secretariat of the changes by **August 25 (Wed.)**. If the Secretariat is not informed, the bill shall be sent based on the original application. In addition, if changes of such as the number of anchor bolts and its positions occur after submitting the application for floor construction, please submit the application for the change as in the above cases.

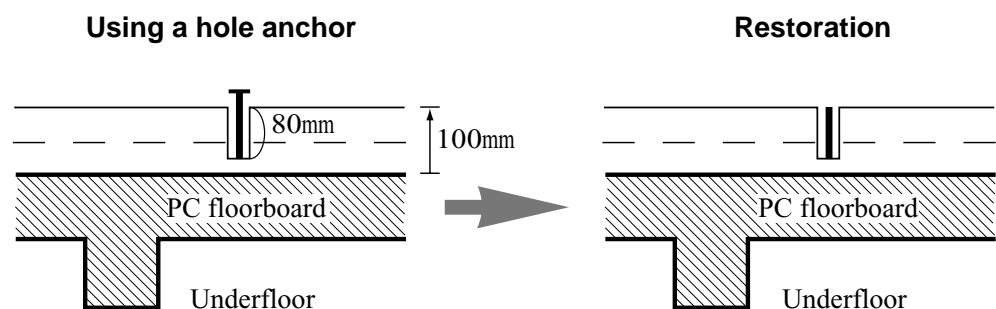

#### 11) Others

On the passage in the venue, including the doorways and escalators, exhibitors are restricted to do any activities which disturb free traffic of visitors, including but not limited to distributing leaflets and/or questionnaires, and calling visitors into your booths.

### 3. Electricity

---

#### (1) Applying for power Supply

Fill out the “Light and Power Installation Blueprint (Form 3)” attached to the end of this brochure, and submit it to the Secretariat by **July 9 (Fri.)**.

#### (2) Power specifications

- 1) The following power specifications are available. Please specify the specifications you require in the “Light and Power Installation Blueprint.”
  - A) AC 100 V, single-phase, 50 Hz
  - B) AC 200 V, single-phase, 50 Hz
  - C) AC 200 V, three-phase, 50 Hz
- 2) The Secretariat will provide wiring services up to the breakers in each of the booths.

#### (3) Electrical installation costs

Please pay the wiring installation charges billed by the Secretariat (after the closing of the show). These charges are based on the following formula:

- 1) Unit price: 9,300 yen per 1 kW of installed capacity (including consumption tax)  
(For single-phase 100 V and 200 V, and three-phase 200 V)
- 2) The installed capacity is calculated as the total capacity shown in your “Light and Power Installation Blueprint.” Fluorescent lamps and high-voltage mercury-arc lamps must be calculated at 1.5 times their rated capacity.

#### (4) Electricity charges

Please pay the charges billed by the Secretariat (after the closing of the show). These charges are based on the following formula:

- 1) Unit price: 1,600 JPY/kW (including consumption tax) (usage below 1 KW would be rounded up to 1 KW)
- 2) The total power is calculated based on the assumption that your total capacity shown in your “Light and Power Installation Blueprint” was used eight hours a day, for four days.

#### (5) Reminders regarding electric installation work within your booth

- 1) All personnel conducting the electric installation work must carry a license, such as the Electric Work Specialist License issued according to the Electric Work Specialist Law, while they work.
- 2) Electrical appliances that are subject to the Electrical Appliance and Material Control Law must display a label showing that the model has been certified by the Minister of Economy, Trade and Industry.
- 3) Heat generating equipment such as incandescent bulbs and resistors must be installed in such a way that they do not make contact to flammable materials or people, or become overheated. The use of neon lights is prohibited.
- 4) Distribution panels and other regulating equipment must be contained in steel or plastic boxes (model certified) and must be installed in a place where they are easy to service and inspect. Please take extra care when installing these in the storage room. Always include the name of the installer and their phone number on the distribution panel.
- 5) Do not use vinyl cords to wire lighting and other equipment. Always use cables with the same capacity as an F cable with a thickness of 1.6 mm or greater. Cable connections must be made by crimping or soldering at the sleeve.
- 6) If you want to run wires on the floors or passages in your booth, use saddle-fixed iron pipes, molding, iron cover plates and rubber mats so that they do not obstruct pedestrian traffic.

- 7) For branching switches in the booth for general purposes: Use breakers or cover switches that meet the capacity of your equipment. Cover switches must be equipped with an appropriate fuse. Never use copper wire or similar objects as a substitute. Do not overload the wirings from the switch.
- 8) When using electricity near water (for equipment that uses both water and electricity, for example), equip the main switch at the distribution panel or the branch switches with a leakage breaker that meets the capacity of your equipment.
- 9) Wiring for lighting outlets must be equipped with one branch switch for each piece of equipment with a capacity of 15 A or greater. Otherwise, group your equipment for a total of 15 A or less into single circuits and use a branch switch for each circuit.
- 10) Equipment with a voltage to ground of 150 V or greater must be securely grounded. (If your distribution panel is enclosed in a steel box, always ground the casing.)
- 11) During construction, take special care to prevent electrical accidents including fires, personal injury and property damage. No construction work shall be permitted under any circumstances once the show has started, so make sure to complete your construction before the show starts.

#### **(6) Hours of power supply to your booth**

- 1) Power will be supplied from 9:00 AM on August 31 (Tues.) to 5:00 PM on September 3 (Fri.).
- 2) Exhibitors needing power supply on August 30 (Mon.) are required to apply to the Organizer Secretariat at Hall 5 (prior notification is not needed)
- 3) During the show, power will be supplied between 9:00 AM to 5:00 PM.

#### **(7) 24-hour power supply**

If your exhibit requires a 24-hour power supply, **make sure to indicate this** in your “Light and Power Installation Blueprint” (Form 3) **using red ink**. Also make sure that the electric installation contractor for your booth and the power mains installer go over the details before the installation.

#### **(8) Others**

- 1) An electrical maintenance attendant will be stationed at the Secretariat Office during the show.  
Please contact the Secretariat ASAP in the event of an electrical accident in your booth.
- 2) The power mains installation work will be performed by the following company.  
Please contact their office for questions regarding the power mains installation.

**Iida Electrical Industry INC.** (contact persons: Fukuhisa, Nakamura)  
1-8-21 Shinkiba, Koto-ku, Tokyo, 136-0082  
Phone: (03)3521-3522 Fax: (03)3521-3524

**Chiba Sales Office**  
2-38 Hamada, Mihama-ku, Chiba City, Chiba, 261-0025, Japan  
Phone: (043) 273-2441 Fax: (043) 273-2531

## 4. Fire Safety

---

The Fire Service Law generally prohibits smoking and the use of open flames in the venue, as well as carrying in of hazardous substances. However, if such activities or substances are essential to your exhibit, the Secretariat will file an “Application for Authorized Cancellation of Prohibited Activities” with the fire department, which will allow you to perform such activities or use such substances.

From the fire safety standpoint, observe the following rules regarding smoking and the use of open flames in the hall, and the carrying in of hazardous substances.

### (1) No smoking policy

Please make sure that this non-smoking policy is fully understood by everyone who enters the venue including drayage contractors and decorators.

- 1) All the booths and Halls 4, 5, 6, 7 and 8 are a NO SMOKING AREA at all times including installation and dismantling periods. In particular, smoking in the corners, door side and stair area of the halls during installation & dismantling time, by the related workers is often seen. Please thoroughly inform your workers of the no smoking policy under your responsibility in controlling the installing and dismantling works.
- 2) Indoor common spaces in Makuhari Messe, such as passages, malls, and lobbies are also NO SMOKING. Smoking is permitted only in the designated areas, “Ikoi” Mall located between Halls 6 and 7 and “Yasuragi” Mall between hall 3 and 4.
- 3) Starting from installation to the end of dismantling, when someone was found smoking outside the designated smoking area, the smoker and the responsible exhibitor management should submit the official paper of apology to the Show Office.

### (2) Use of open flames and hazardous substances

The following criteria must be met:

- 1) If you plan to use open flames or carry in any of the Class 4 hazardous substances listed below, submit the “Application for the Use of Open Flames and Hazardous Substances (Form 4)” attached to the end of this brochure to the Secretariat by **July 9 (Fri.)**.
- 2) For hazardous substances that you will be using for your demonstrations: Each day, carry in only the amount needed for that day.
- 3) Platforms and the near areas where the open flame will be used must be covered with non-flammable materials other than metals.
- 4) The use of fire or sparks near the hazardous substances is prohibited.
- 5) Handle the container with care to prevent it from tipping over or the substance from leaking.
- 6) Install a fire extinguisher and mark its location clearly.

#### **Type of hazardous substance (Class 4)**

- Special inflammable substances (ex. diethylether and carbon disulfide)
- Type 1 oils (ex. gasoline, thinner and acetone)
- Alcohols
- Type 2 oils (ex. kerosene and diesel oil)
- Type 3 oils (ex. grade-A heavy oil, mechanical oil and creosote oil)
- Type 4 oils (ex. spindle oil, gear oil, lubricants and hydraulic fluid)
- Animal and vegetable oils (ex. edible oils)

**Other fire hazards and hazardous substances:** spray oil, turpentine oil, benzol, chlor, concentrated sulphuric acid, nitrogen gas, argon gas, propane gas, pressurized gas, freon gas, carbon gas, large amount of matches, celluloids, ammonia and washing liquids for machines.

### (3) Other reminders

- 1) **Fire extinguishers must be installed at easy-to-locate places near areas where their installation is mandated, including the areas where hazardous substances will be used.**
- 2) **Prior to the opening of the show, protective plastic tarps used on the carpets during installation must be removed from all areas including from underneath the exhibit platforms and inside the storage room.**

## 5. Phone, Fax, ADSL/ISDN/Optical Fiber Cable

If you require a phone and/or fax in your booth, file an application with the Secretariat.

### (1) Application

Please apply using the "Application for Temporary Phone and Fax (Form 5)" attached to the end of this brochure at the Secretariat by **July 9 (Fri.)**.

### (2) Charges

You will be charged for installation, basic charges and call charges after the show. Please transfer your payment to the Secretariat by the specified date.

	Phone	ISDN	ADSL	Optical Fiber
Installation (per line)	12,000 yen Includes machine rental	24,000 yen Includes machine rental	Approx. 55,000 yen Whole set	Approx. 84,000 yen Whole set
Basic charges (per line)	3,000 yen	5,000 yen		
Call charges	Actual charges		Not necessary	

- The above prices include consumption tax as well as equipment rental charges.
- The installation (connection) fee shall be charged even when machine was unnecessary.
- Fax machine rental fee is 9000 yen for three days, installation and removal 11000 yen in addition to phone charges.
- Fax machines are limited in quantity.
- ISDN fee has been changed because of the price change at NTT.
- The ADSL set includes router, modem and provider fee and the price is an example of a service using NTT East ADSL 12 M, including equipment listed above and service provider. The router can accommodate up to four cables. Cables used between the router and a personal computer are to be prepared by exhibitors. The price varies depending on whether you are using your own equipment and service provider, and on the number of computers you are using. For details, please contact the Secretariat ahead of time.
- High speed optical fiber connection set includes line, dynamic IP, router and provider fee. The HUBs need to be prepared by exhibitor. If exhibitor preferred to have fixed IP address, please consult organizer.

### (3) Notification of phone number

The exhibitors' contact person for the JAIMA EXPO / SIS will be informed of the assigned phone number, ten days to two weeks ahead of the SHOW.

### (4) Others

- 1) Do not apply at the telephone company directly as this would cause unnecessary confusion.
- 2) The exhibitors who use the Internet via ADSL should take necessary network security measures on their own responsibility.

## 6. Water Supply, Drainage and Compressed Air

When an exhibitor requires a water supply, make sure to file an application with the Secretariat before you begin the installation work.

**(1) Installation** The exhibitor is responsible for all installation work and its costs.

**(2) Costs** The user (exhibitor) is responsible for the costs for basic facilities and the water usage charges.

**(3) Others** 1) The following company is available for plumbing work. Please call them directly.

**Yamazaki Kogyo-sho K. K.** (contact person: Katsuya)  
 4-23-17 Honcho, Nakano-ku, Tokyo, 164-0012, Japan  
 Phone: (03) 3383-3541 Fax: (03) 3380-1298

- 2) If you have any questions, please contact the Secretariat ASAP.

## 7. Rental Meeting Rooms and Lounges

Starting from this year, the meeting rooms on the first level and gests lounges on the second level of the exhibition halls become available for rent. The order shall be served in order of arrival.

- Applicants: Limited to the exhibitors of JAIMA EXPO 2010 / SIS 2010. (General & Independent booth exhibitors)
- Application: Fill out the Form 10 to apply.
- Usage: Meeting, Business, Storage and Waiting room. \* Exhibition or seminars are prohibited.

### (1) Meeting Rooms on the first level of exhibition halls

- Dates: From August 31 through September 3, Four days (9:00 \_ 17:00)  
\* Daily rental is not available.
- Rooms, Furniture and Fees

Hall	Area	Furniture		Fee (4days)
		(tables)	(folding chairs)	
4 (1 room)	80 m <sup>2</sup> 13.2m × 6m	10	30	210,000 yen
5 (1 room)	112 m <sup>2</sup> 18.7m × 6m	14	42	250,000 yen
6 (1 room)	80 m <sup>2</sup> 13.2m × 6m	10	30	210,000 yen
7 (1 room)	112 m <sup>2</sup> 18.7m × 6m	14	42	250,000 yen

\* If exhibitors require other furnishings, please consult organizer.

### (2) Gests Lounges on the second level of exhibition halls

(3 rooms, 1 room for each of 4, 6 and 8 halls) Areas are 96 m<sup>2</sup> (12m × 8m)

- Dates: From September 1 to September 3, 10:00 \_ 17:00 \*Hourly rental available.  
The lounge at hall 6 starts at 11:00 on September 1.  
Minimum rental hour is 1 hour.
- Fee: 20000 yen / hour\*room
- Furniture: 2 sets of sofas & table (for 8 people), refrigerator (with 12 tea bottles and 12 water bottles)

## 8. Servicing Foods or Beverages

- 1) Serving alcohol beverage is restricted.
- 2) When exhibitor plans to serve foods and/or beverages to the visitors, please consult local Health Office indicated below. And please submit a notification to the Show Office using the attached form 11. (Due date August 2 (Mon.))

However, when exhibitor did not use outside service company with no cooking work, (ex. Serving the coffee using coffee maker at the booth.) notification is not necessary.

The Health Office may issue instructions for hygiene purpose, like sterilization and/or water plumbing regulations. Non conformance to the instructions may be resulting in cancellation of foods service.

**Local Health Office:** Chiba city health office, Foods Safety Division  
1-3-9 Saiwai-cho Mihama-ku, Chiba-city 261-8755 Japan  
2nd Fl, Chiba General Health-Care and Clinical Center  
Tel: +81-43(043 within Japan) 238-9934

## ■ List of Forms, Applications and Submission Deadlines

Document to submit		Page of related items	Application deadline	Number of copies to be submitted	Where to submit
Form 1	Decorator Registration Form (prior notification of laying carpet in the passage between opposing booths)	11–20	Friday, July 9	1 copy (mandatory)	JAIMA EXPO 2010 / SIS 2010 Organizing Committee Att. Japan Analytical Instruments Manufacturers' Association
Form 2	Application for Special Construction 1) Decoration for higher than 2.7 m 2) Ceiling structure and 2 story structure 3) Anchor bolts	15–17 20	Friday, July 9	1 copy	
Form 3	Light and Power Installation Blueprint	21–22	Friday, July 9	1 copy (mandatory)	
Form 4	Application for the Use of Open Flames and Hazardous Substances	23	Friday, July 9	1 copy	
Form 5	Application for Temporary Phone, Fax, ADSL/ISDN/Optical Fiber	24	Friday, July 9	1 copy	
Form 6	Application for the Use of Drayage Machinery	12	Friday, August 6	1 copy	Cap K. K.
Form 7	Confirmation Request for Products Needing Application for Industrial Property Right	6	Monday, August 2	1 copy	JAIMA EXPO 2010 / SIS 2010 Organizing Committee Att. Japan Analytical Instruments Manufacturers' Association
Form 8	Application for Change of Address or Number of Nametags for Exhibitors	7	Friday, July 16	1 copy	
Form 9	Application for Bar Code Registration System	8	Friday, July 9	1 copy	
Form 10	Application for Meeting Rooms and Gests Lounges Rental	25	Friday, July 9	1 copy	
Form 11	Notification of Foods & Beverages Service	25	Monday, August 2	1 copy	
	Application for System Panel Booths, Package Displays and Options	Already sent	Friday, July 23	–	TEN Corporation

● **Make sure that the documents are submitted by the deadlines stated above.**

- The forms listed above are attached to the end of this brochure.

Please be sure to make a copy of these documents for your records.

- You can see the pamphlets on the following URLs.

<http://www.jaimashow.jp/english/pdf/entry/pbi.pdf>

[http://www.jaimashow.jp/english/pdf/entry/ot\\_cs\\_of.pdf](http://www.jaimashow.jp/english/pdf/entry/ot_cs_of.pdf)

JAIMA EXPO 2010 / SIS 2010

# Decorator Registration Form

Prior Notification of laying carpet in the passage between opposing booths (8 or more booths)

Company name: \_\_\_\_\_ Booth No. \_\_\_\_\_

Address: \_\_\_\_\_ Phone: \_\_\_\_\_

\_\_\_\_\_ Fax: \_\_\_\_\_

PIC: Section \_\_\_\_\_ Name: \_\_\_\_\_

**Deadline: Submit one copy by Friday, July 9.**

**Submit to: JAIMA EXPO 2010 / SIS 2010 Organizing Committee**

**Att. Japan Analytical Instruments Manufacturers' Association**

webmaster@jaima.or.jp Phone: (03) 3292-0642 Fax: (03) 3292-7157

Our decorator's information is as follows:

Name of decorator	
Address	
Phone	
Fax	
PIC	

- Move-in time: 8:00 – 17:00, Monday, August 30, and  
8:00 – 15:00, Tuesday August 31
- Move-out time: 17:00 – 24:00, Friday, September 3
- Vehicle entrance: South Gate 2
- Waste material: Always take waste material and carpets out of the venue and dispose.

Cut here

JAIMA EXPO 2010 / SIS 2010

# Application for Special Construction

1) Decoration for height of 2.7 m or more 2) Ceiling or two-floor structures 3) Anchor bolts

Company name: \_\_\_\_\_ Booth No. \_\_\_\_\_

Address: \_\_\_\_\_ Phone: \_\_\_\_\_

\_\_\_\_\_ Fax: \_\_\_\_\_

PIC: Section \_\_\_\_\_ Name: \_\_\_\_\_

Billing address if different from above:

Company name:	Phone:
Address:	Fax:
PIC: Section:	Name:

**Deadline: Submit one copy by Friday, July 9.**

**Submit to: JAIMA EXPO 2010 / SIS 2010 Organizing Committee**

**Att. Japan Analytical Instruments Manufacturers' Association**

Sakura Bldg., 3rd Floor, 1-10-1 Kanda-Nishiki-cho, Chiyoda-ku, Tokyo, 101-0054 Japan

Phone: (03) 3292-0642 Fax: (03) 3292-7157

We are applying to perform the following installation work:

1) Decoration for height of 2.7 m or more		Yes	/	No	(Circle either.)
2) Ceiling structures / Two-floor structures		(Circle either.) Planned to be constructed			
3) Floor work (insertion of anchor bolts)		Anchors must be no longer than 80 mm and no thicker than 12 mm.			
Details of work 3)	Number of locations	Number of anchors per location	Total number of anchors	Bolt thickness	
	location(s)	anchor(s)	anchor(s)	mm	
Installer	Company name				
	Address			Phone	
				Fax	
PIC					

\* Attach two copies of blueprints in any case of 1) to 3), by Friday, August 1.

\* Always observe the "Construction reminders" (pages 15 to 20), "Construction of ceiling or two-floor structures" (pages 15 and 16), and "Floor work" sections (pages 20).

\* If you add changes for 3), please inform the Secretariat of the changes by August 29. If you do not, the Secretariat will send a bill to you according to the above mentioned application.

# JAIMA EXPO 2010 / SIS 2010 Light and Power Installation Blueprint

Company name: \_\_\_\_\_ Booth No. \_\_\_\_\_

Address: \_\_\_\_\_ Phone: \_\_\_\_\_

\_\_\_\_\_ Fax: \_\_\_\_\_

PIC: Section \_\_\_\_\_ Name: \_\_\_\_\_

**Deadline: Submit one copy by Friday, July 9.**

**Submit to: JAIMA EXPO 2010 / SIS 2010 Organizing Committee**

**Att. Japan Analytical Instruments Manufacturers' Association**  
webmaster@jaima.or.jp Phone: (03) 3292-0642 Fax: (03) 3292-7157

Please have your contractor fill out this form, (when your contractor were not fixed please consult IIDA Electric Corp..

Power mains installer:		Iida Electrical Industry INC.				1-8-21 Shinkiba, Koto-ku, Tokyo, 136-0082 Phone: (03)3521-3522 Fax: (03)3521-3524			
In-booth electrical installer		Name _____				Phone _____			
		Address _____				Fax _____			
Lighting 100V	Appliance name & capacity	W	W	W	W			Total	Total capacity
	Quantity								
Power 200V	Capacity	kW	kW	kW	kW			Total	Total capacity
	Quantity								

(Note) If you are using single-phase 200V, indicate this clearly.

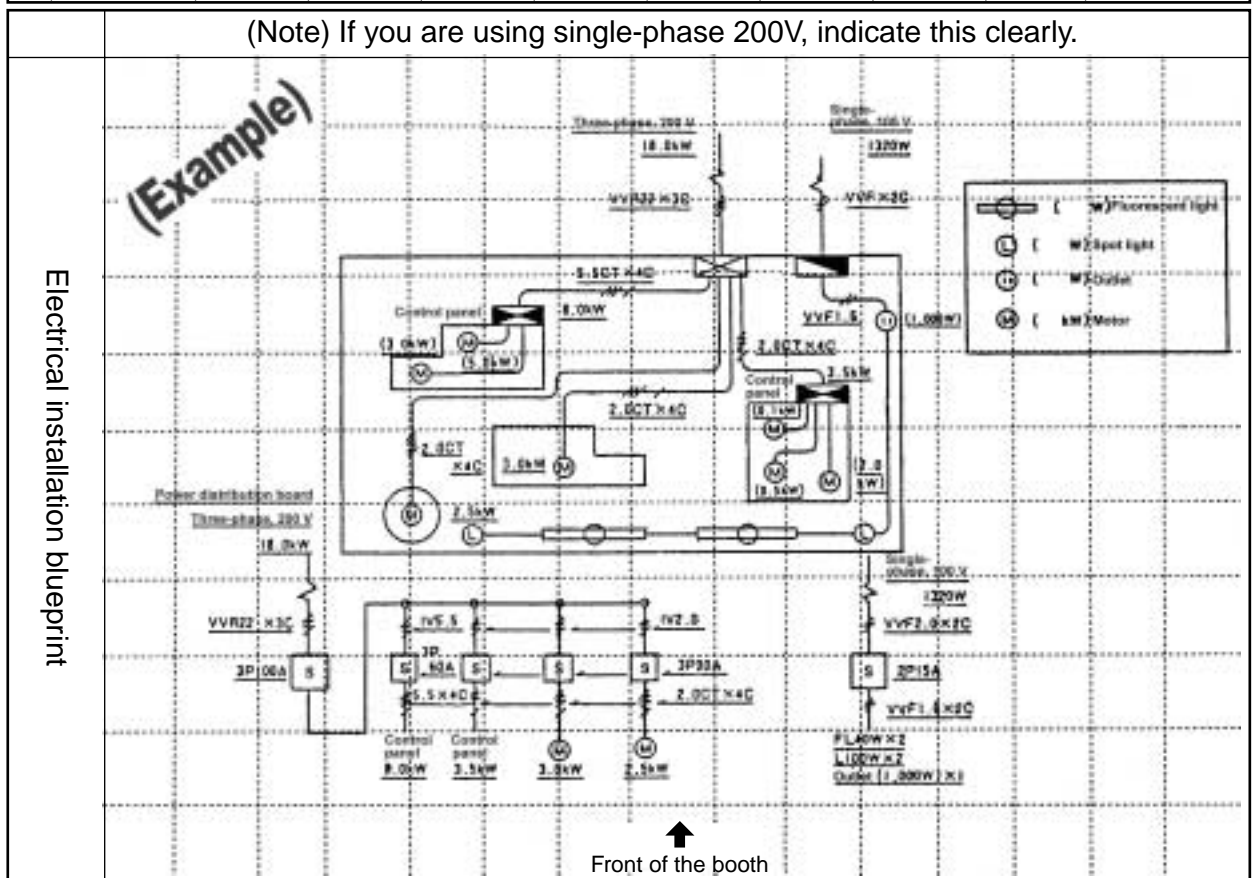

- Notes
1. Describe the wattage with an abbreviation of appliance. For example, FL40W indicates fluorescent lights of 40 W, and L100W indicates incandescent lights of 100 W, etc.
  2. Multiply the total capacity for fluorescent lamps and high-voltage mercury-arc lamps by 1.5.
  3. If you are unable to include the wiring and connection diagrams in this form, write "See attachment," and attach the diagrams on a separate sheet.
  4. If you require 24-hour power supply, indicate this in red ink.

JAIMA EXPO 2010 / SIS 2010

# Light and Power Installation Blueprint

Company name: \_\_\_\_\_ Booth No. \_\_\_\_\_

Address: \_\_\_\_\_ Phone: \_\_\_\_\_

\_\_\_\_\_ Fax: \_\_\_\_\_

PIC: Section \_\_\_\_\_ Name: \_\_\_\_\_

Billing address if different from above:

Company name:	Phone:
Address:	Fax:
PIC: Section:	Name:

**Deadline: Submit one copy by Friday, July 9.**

**Submit to: JAIMA EXPO 2010 / SIS 2010 Organizing Committee**

**Att. Japan Analytical Instruments Manufacturers' Association**

webmaster@jaima.or.jp Phone: (03) 3292-0642 Fax: (03) 3292-7157

Please have your contractor fill out this form, (when your contractor were not fixed please consult IIDA Electric Corp..)

Power mains installer:	Iida Electrical Industry INC.		1-8-21 Shinkiba, Koto-ku, Tokyo, 136-0082 Phone: (03)3521-3522 Fax: (03)3521-3524						
In-booth electrical installer	Name				Phone				
	Address				Fax				
Lighting 100V	Appliance name & capacity	W	W	W	W			Total	Total capacity
	Quantity								
Power 200V	Capacity	kW	kW	kW	kW			Total	Total capacity
	Quantity								

(Note) If you are using single-phase 200V, indicate this clearly.

Electrical installation blueprint																						

↑  
Front of the booth

- Notes
1. Describe the wattage with an abbreviation of appliance. For example, FL40W indicates fluorescent lights of 40 W, and L100W indicates incandescent lights of 100 W, etc.
  2. Multiply the total capacity for fluorescent lamps and high-voltage mercury-arc lamps by 1.5.
  3. If you are unable to include the wiring and connection diagrams in this form, write "See attachment," and attach the diagrams on a separate sheet.
  4. If you require 24-hour power supply, indicate this in red ink.

Cut here

JAIMA EXPO 2010 / SIS 2010

# Application for the Use of Open Flames and Hazardous Substances

---

Company name: \_\_\_\_\_ Booth No. \_\_\_\_\_

Address: \_\_\_\_\_ Phone: \_\_\_\_\_

\_\_\_\_\_ Fax: \_\_\_\_\_

PIC: Section \_\_\_\_\_ Name: \_\_\_\_\_

**Deadline: Submit one copy by Friday, July 9.**

**Submit to: JAIMA EXPO 2010 / SIS 2010 Organizing Committee  
Att. Japan Analytical Instruments Manufacturers' Association  
webmaster@jaima.or.jp Phone: (03) 3292-0642 Fax: (03) 3292-7157**

**We are applying for the use of the following hazardous substances.**

\* Indicate the types of hazardous substances and the amounts you will be using per day.

Cut here

JAIMA EXPO 2010 / SIS 2010

# Application for Temporary Phone and Fax ADSL/ISDN/ Optical Fiber Line

Company name: \_\_\_\_\_ Booth No. \_\_\_\_\_

Address: \_\_\_\_\_ Phone: \_\_\_\_\_

\_\_\_\_\_ Fax: \_\_\_\_\_

PIC: Section \_\_\_\_\_ Name: \_\_\_\_\_

Billing address if different from above:

Company name:	Phone:
Address:	Fax:
PIC: Section:	Name:

**Deadline: Submit one copy by Friday, July 9.**

**Submit to: JAIMA EXPO 2010 / SIS 2010 Organizing Committee**

**Att. Japan Analytical Instruments Manufacturers' Association**  
webmaster@jaima.or.jp Phone: (03) 3292-0642 Fax: (03) 3292-7157

We are applying for the installation of the following temporary phone and/or fax:

Phone: \_\_\_\_\_ line(s) Phone equipment: Exhibitor's equipment / Lease

Fax equipment: Exhibitor's equipment / Lease

ISDN: \_\_\_\_\_ line(s) DSU: Exhibitor's equipment / Lease

ADSL: \_\_\_\_\_ line(s)

Optical Fiber: \_\_\_\_\_ line(s)

**Indicate the location of the equipment in your booth.**

Cut here

JAIMA EXPO 2010 / SIS 2010

**Application for the Use of Drayage Machinery (for a charge)**

Company name: \_\_\_\_\_ Booth No. \_\_\_\_\_

Address: \_\_\_\_\_ Phone: \_\_\_\_\_

\_\_\_\_\_ Fax: \_\_\_\_\_

PIC: Section \_\_\_\_\_ Name: \_\_\_\_\_

Billing address if different from above:

Company name:	Phone:
Address:	Fax:
PIC: Section:	Name:

**Deadline: Friday, August 6.****Submit to: Cap K. K.**4-25-18 Higashi-Shinkoiwa, Katsushika-ku, Tokyo, 124-0023  
Phone: +81-3-3695-0623 Fax: +81-3-3695-3088**We are applying to use the following drayage machinery:**

(Circle all applicable items on lines marked with "**".)				
Number of items:		* Packing style:	Unpacked	Packed
Weight:	Maximum weight per item: ( ) kg / Total weight: ( ) kg			
Volume:	Maximum volume per item: Length ( ) × width ( ) × height ( )			
* Mode of transport:	1 Automobile	2 Container	3 Mixed parcels	4 Others
* Entity responsible for transport:	1 Cap Co., Ltd.	2 Exhibitor	3 Transport company appointed by the exhibitor	
* Hall workers:	1 Cap Co., Ltd.	2 Exhibitor	3 Company appointed by the exhibitor	
* Insurance:	1 Comprehensive exhibit insurance	2 Transportation insurance	3 Others	If you require insurance, please call Cap Co., Ltd.
Insured amount:	¥			
* Type of vehicle:	4-ton truck: ( ) truck(s)	10-ton truck: ( ) trucks(s)	Fork lift or tow truck	
Remarks:				

Cut here

JAIMA EXPO 2010 / SIS 2010

# Confirmation Request for Products Needing Application for Industrial Property Right

---

\* Please note that the submission of this document in itself does not complete the application for the Exhibit Certificate. The Exhibit Certificate shall be issued to you only when you request your Exhibit Certificate within seven days after the show.

For more details, please contact the Secretariat.

Company name: \_\_\_\_\_

Address: \_\_\_\_\_

Please inform the Secretariat of your choices for date and time for the confirmation of your products, between September 1 (Wed.) and September 3 (Fri.).

(Please specify your three alternatives, when the person in charge of your exhibits can join the confirmation from the Secretariat. The confirmation is usually completed in a few minutes.)

First choice:      Date: September \_\_\_\_\_ ,      Time: \_\_\_\_\_

Second choice:    Date: September \_\_\_\_\_ ,      Time: \_\_\_\_\_

Third choice:      Date: September \_\_\_\_\_ ,      Time: \_\_\_\_\_

**Deadline: Submit one copy by Monday, August 2.**

**Submit to: JAIMA EXPO 2010 / SIS 2010 Organizing Committee  
Att. Japan Analytical Instruments Manufacturers' Association  
webmaster@jaima.or.jp    Phone: (03) 3292-0642    Fax: (03) 3292-7157**

JAIMA EXPO 2010 / SIS 2010

# Application for Change of Address or Number of Nametags for Exhibitors & Contractors

10 tags per booth for exhibitors and 5 tags per booth for contractors will be supplied to each exhibitor. (The nametags will be sent to the person in charge for the Exposition in the beginning of August.) If you need more than or less than these number of tags, or change the address to which the nametags to be sent, please apply by filling out the following.

## •• Change of address to sent ••

Change    Yes / No    (Only in the case of Yes, please fill out the following.)

Company name: \_\_\_\_\_

Address: \_\_\_\_\_

PIC: Section: \_\_\_\_\_

Name: \_\_\_\_\_

Phone: \_\_\_\_\_

Fax: \_\_\_\_\_

## •• Change of number of tags ••

Change    Yes / No    (Only in the case of Yes, please fill out the following.)

<b>New number of exhibitor tags:</b>	<b>Tags</b>
<b>New number of contractor tags:</b>	<b>Tags</b>

**Deadline: Submit one copy by Friday, July 16.**

**Submit to: JAIMA EXPO 2010 / SIS 2010 Organizing Committee**

**Att. Japan Analytical Instruments Manufacturers' Association**  
webmaster@jaima.or.jp    Phone: (03) 3292-0642    Fax: (03) 3292-7157

JAIMA EXPO 2010 / SIS 2010

# Application for Lead Retrieval System

**Deadline: Friday, August 2 (Monday)**

**Submit to:** TAIYODO Co., Ltd.

4 Saiin-kamihanada-cho Ukyo-ku, Kyoto 615-0007 Japan

Phone: (03) 3292-0642 Fax: (03) 3292-7157

Exhibitor name: \_\_\_\_\_ Booth No. \_\_\_\_\_

Address: \_\_\_\_\_ Phone: \_\_\_\_\_

\_\_\_\_\_ Fax: \_\_\_\_\_

Section name: \_\_\_\_\_ Responsible person: \_\_\_\_\_

Application date: \_\_\_\_\_ e-mail: \_\_\_\_\_

Confirmation to be:       e-mail / mail      

Request for presentation:       date 1                    date 2                    date 3      

## 1. Bar code system

	Plan, (Option)	Unit Price	Units
Plan A	Standard	12,600 yen	set
	Plus	15,720 yen	set
	w/Handy Terminal	9,450 yen	unit
Plan B	Type S	57,500 yen	set
	Type 1	47,250 yen	set
	Type 2	42,000 yen	set
	Type 3	31,500 yen	set
Options	Bar Code Label (To relate questionnaires and visitor badges)	945 yen	set
	Report Generation Service (For Plan A)	10,500 yen	set
Consumables	Battery (for Plan A)	315 yen	set
	Thermal Paper (for Plan B Type S)	525 yen	roll
	Thermal Paper (for Plan B Type 1)	525 yen	roll
	A6 Paper (for Plan B Type 2 & 3)	525 yen	set
	Printer Ink (for Plan B Type 2)	1,050 yen	unit
	Printer Ink (for Plan B Type 3)	2100 yen	set

## 2. Billing address if different from the above address:

Company name:	PIC:
Section name:	
Address:	
Phone:	Fax:

At the JAIMA EXPO 2010 / SIS 2010, we will observe the following rule when we handle personal information acquired from bar codes.

1. We shall never resell personal data acquired.
2. We shall use personal data only within our company and never divert it to other companies.
3. We shall take measures to confirm the individual's consent when using personal data, and if an individual refuses our use of the corresponding individual data such as offering or communicating the data to the third parties, we shall immediately stop the use of the data.

Cut here

JAIMA EXPO 2010 / SIS 2010

# Application for Meeting Rooms and Guest Lounges rental

Exhibitor name: \_\_\_\_\_ Booth No. \_\_\_\_\_  
 Address: \_\_\_\_\_ Phone: \_\_\_\_\_  
 \_\_\_\_\_ Fax: \_\_\_\_\_  
 Section name: \_\_\_\_\_ Responsible person: \_\_\_\_\_  
 Application date: \_\_\_\_\_ e-mail: \_\_\_\_\_

## Billing address if different from the above address:

Company name:	PIC:
Section name:	
Address:	
Phone:	Fax:

## Deadline: Submit one copy by Friday, July 9

Submit to: JAIMA EXPO 2010 / SIS 2010 Organizing Committee  
 Att. Japan Analytical Instruments Manufacturers' Association  
 webmaster@jaima.or.jp Phone: (03) 3292-0642 Fax: (03) 3292-7157

## We hereby apply for meeting room / guest lounge rental

Meeting room at	4 days rental fee (tax and electric charge included)	circle your choice
hall 4	¥210,000	
hall 5	¥250,000	
hall 7	¥210,000	
hall 8	¥250,000	
Total		¥

guest lounge at	use date & time	fee (¥20,000 / hour•lounge)
hall 4	Sep. _____ : _____ : _____	¥
hall 4	Sep. _____ : _____ : _____	¥
hall 4	Sep. _____ : _____ : _____	¥
hall 4	Sep. _____ : _____ : _____	¥
hall 4	Sep. _____ : _____ : _____	¥
hall 4	Sep. _____ : _____ : _____	¥
hall 4	Sep. _____ : _____ : _____	¥
hall 4	Sep. _____ : _____ : _____	¥
Total		¥

Cut here



**■ List of contact addresses of the Secretariat and companies assigned  
by the JAIMA EXPO / SIS Organizer**

<b>JAIMA EXPO 2010 / SIS 2010 Secretariat Office</b>	<b>Att. Japan Analytical Instruments Manufacturers' Association</b> Sakura Bldg., 3rd Floor, 1-10-1 Kanda-Nishiki-cho, Chiyoda-ku, Tokyo, 101-0054 Japan Phone: (03) 3292-0642 Fax: (03) 3292-7157 The Secretariat Office will be opened at the North Room in Exhibition Hall 5 and 7 from August 30 to September 3.	Contact persons: Hayashi, Ogawa, Tabayashi
<b>Basic booth decoration,  System panel booth decoration</b>	<b>TEN Corporation</b> 1-5-9 Kotobuki, Taitou-ku, Tokyo, 111-0042 Japan Phone: (03) 3842-7710 Fax: (03) 3842-7720	Contact persons: Aoki, Yamazaki
<b>Power mains installation work</b>	<b>Iida Electrical Industry INC.</b> 1-8-21 Shinkiba, Koto-ku, Tokyo, 136-0082 Phone: (03)3521-3522 Fax: (03)3521-3524 Chiba Sales Office 2-38 Hamada, Mihama-ku, Chiba City, Chiba, 261-0025, Japan Phone: (043) 273-2441 Fax: (043) 273-2531	Contact persons: Fukuhisa, Nakamura
<b>Water supply and drainage</b>	<b>Yamazaki Kogyo-sho K. K.</b> 4-23-17 Honcho, Nakano-ku, Tokyo, 164-0012, Japan Phone: (03) 3383-3541 Fax: (03) 3380-1298	Contact person: Katsuya
<b>Drayage</b>	<b>Cap K. K.</b> 4-25-18 Higashi-Shinkoiwa, Katsushika-ku, Tokyo, 124-0023, Japan Phone: (03) 3695-0623 Fax: (03) 3695-3088	Contact person: Ohkawara
<b>Foreign goods</b>	<b>ISHIKAWA-GUMI. LTD.</b> 5-9-4 Higashi-Shinagawa, Shinagawa-ku, Tokyo, 140-0002, Japan Phone: (03) 3474-8102 Fax: (03) 5460-9841	Contact person: Nozaki
<b>Lead Retrieval system</b>	<b>TAIYODO Co., Ltd.</b> 4 Saiin Kamihanada-cho Ukyo-ku, Kyoto, 615-0007, Japan Phone: +81-75-323-9329 Fax: +81-75-321-5804	Contact persons: Taniguchi, Kato, Yoshida, Uchida
<b>Security service</b>	<b>TEXS K.K.</b> Sun Youth Bl. 3rd floor, 5-40-9 Higashi-Ikebukuro, Toshima-ku, Tokyo, 170-0013, Japan Phone: (03) 3590-6446 Fax: (03) 3590-4001	Contact person: Sueda
<b>SHOW venue</b>	<b>Makuhari Messe, Inc.</b> Nakase 2-1, Mihama-ku, Chiba City, Chiba, 261-0023 Japan Phone: (043) 296-0525 Fax: (043) 296-0529	Contact persons: Hayashi, Kudo

"Please dial your International Calling Code +81-xx-xx..."